

# Semiconductors for the Harshest Environments



Keeping defense platforms viable

Enabling the latest space constellations

## Overall HiRel Process Flow

Teledyne e2v HiRel offers qualification, screening and test capability second to none in the industry. At a time when many semiconductor companies are exiting the hi-rel business in favor of larger markets, we have continued to invest.

Each product offering begins with the wafer which can be fabricated by Teledyne, provided by our customers, or pulled from our vast wafer bank of hard to find and obsolete components from companies that have exited the market. We can also take customer's already packaged devices and test and qualify them as needed.

The output are semiconductor parts screened to levels you specify, ranging from the off-the-shelf versions of the latest radiation tolerant RF and power devices, legacy hard-to-find parts for defense platforms, through to fully custom parts or multi-chip modules.

We'll take a brief tour of these core capability in the following pages.

### 1. Qualification Types

In applications where devices must work in space for years with no excuses, we can offer hermetic packaging and full QML-V certification. However, for many military and space constellation applications, the economics and schedule simply won't allow for such exacting screening and qualification.

For many applications, it makes most sense to use lower-cost packaging including plastic, and to tailor the qualification. For example, if the application is for a defined and relatively short duration, or the degree of radiation exposure expected is low, this allows us to work with you to take cost and time out of the process.

We can advise on where it makes sense to cut costs, and the risk trade-offs involved, in order to agree a custom SCD that will work for your application.

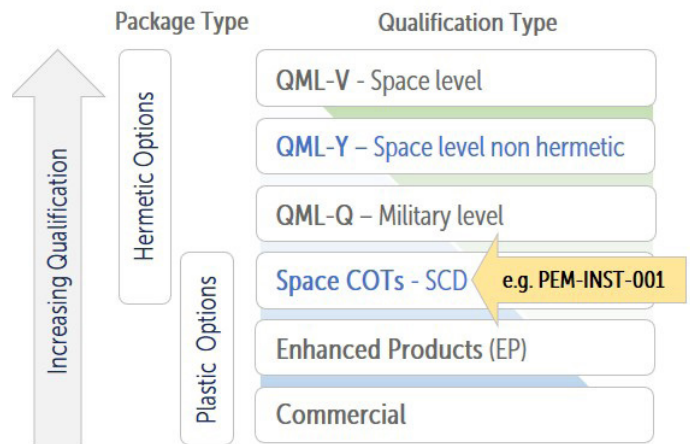
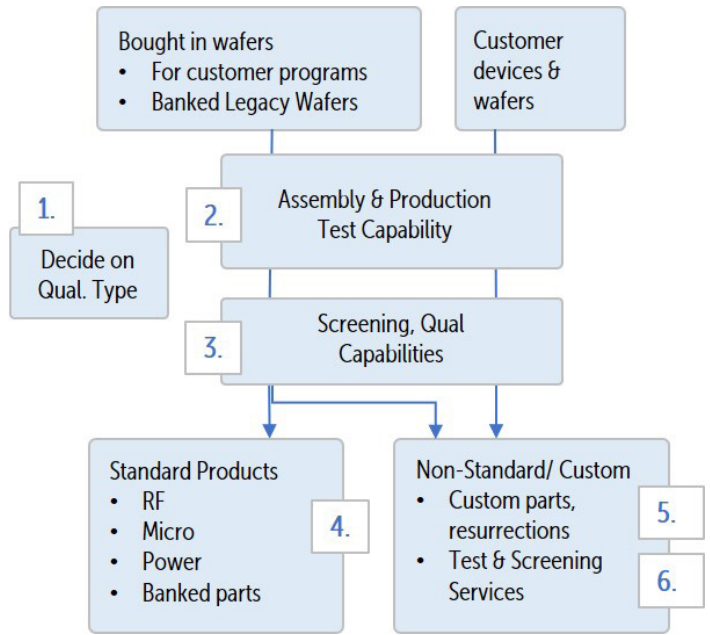

### Certifications & Capabilities

- AS9100/ ISO9001
- DOD DMEA Trusted Supplier
- ISO 9001: 2015
- ITAR Registered
- NASA PEM-INST-001
- Space COTS
- MIL-PRF-38534 Class H
- MIL-PRF-38535 Class B
- MIL-PRF-38535 Class Q
- MIL-PRF-38535 Class V
- MIL-STD-750
- MIL-STD-883

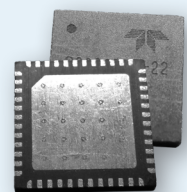

## 2. Assembly & Test Capabilities

### Assembly & Packaging

We are able to perform assembly and packaging in many different formats. Examples include Ceramic, Plastic Encapsulated, and Metal / AISiC Packaging with wide range of standard and custom packages types:

- DIP
- FLATPACK
- QFP
- QFN
- PLCC
- BGA
- PGA
- SMD
- PGA

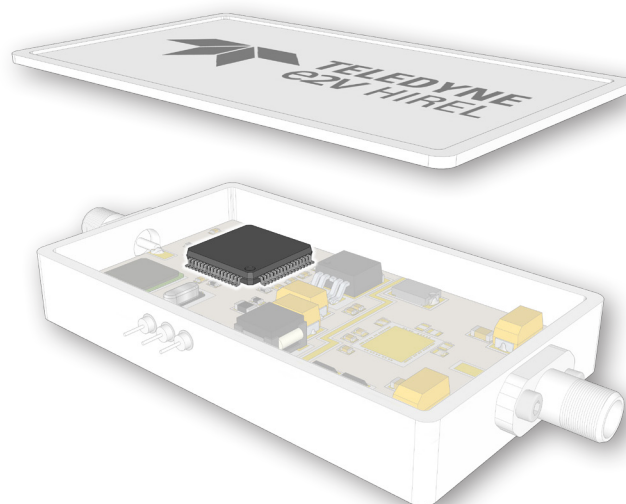
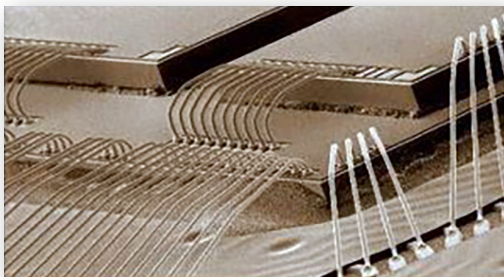

### RF Characterization and Production Test

Testing for our own and customer devices includes:

- Scalable in frequency to 65 GHz
- Scalable in volume from bench characterization to full production testing
- Wide variety of tests and device types
- ATE based with Data reporting summary
- Bench Setups for characterization and verification
- Wafer level probing capability with Cascade microwave probes to 70GHz

Test types include:

- S-parameters
- Phase noise
- Noise figure
- EVM and ACPR
- IIP3
- Etc.



### Power Device Testing

- New customized test development for power parts including radiation tests
- Ability to test up to 200A pulsed and up to 30 kV
- Measurements include surge current, dynamic RDSon, thermal impedance/resistance tests, etc.
- Target devices include wide band gap power devices and ICs such as power management and gate drivers
- Die level high voltage testing

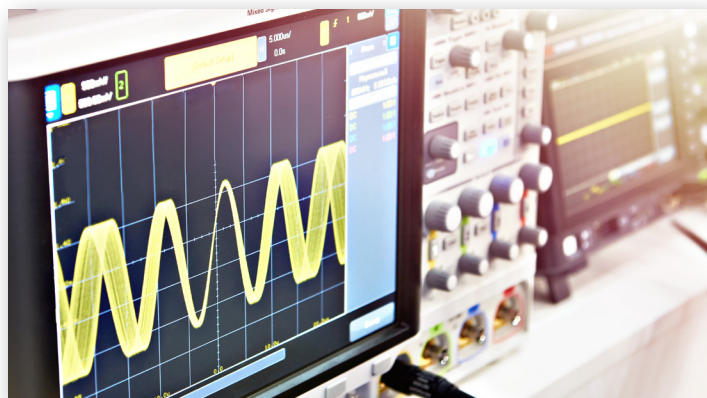



### 3. Screening & Qualification Capabilities

We work closely with you to take your requirements and agree to the right qualification and screening regimes that meet your reliability and cost objectives. This includes custom qualification, custom screening steps, test design and wafer sourcing. The example below shows a typical process flow, then tailored to the needs of a customer SCD for a plastic packaged part. Our facility in Milpitas, California is fully equipped with shake, rattle and roll equipment, ovens, test board design, test equipment and knowledgeable personnel to meet your needs.

#### Custom Flow Example

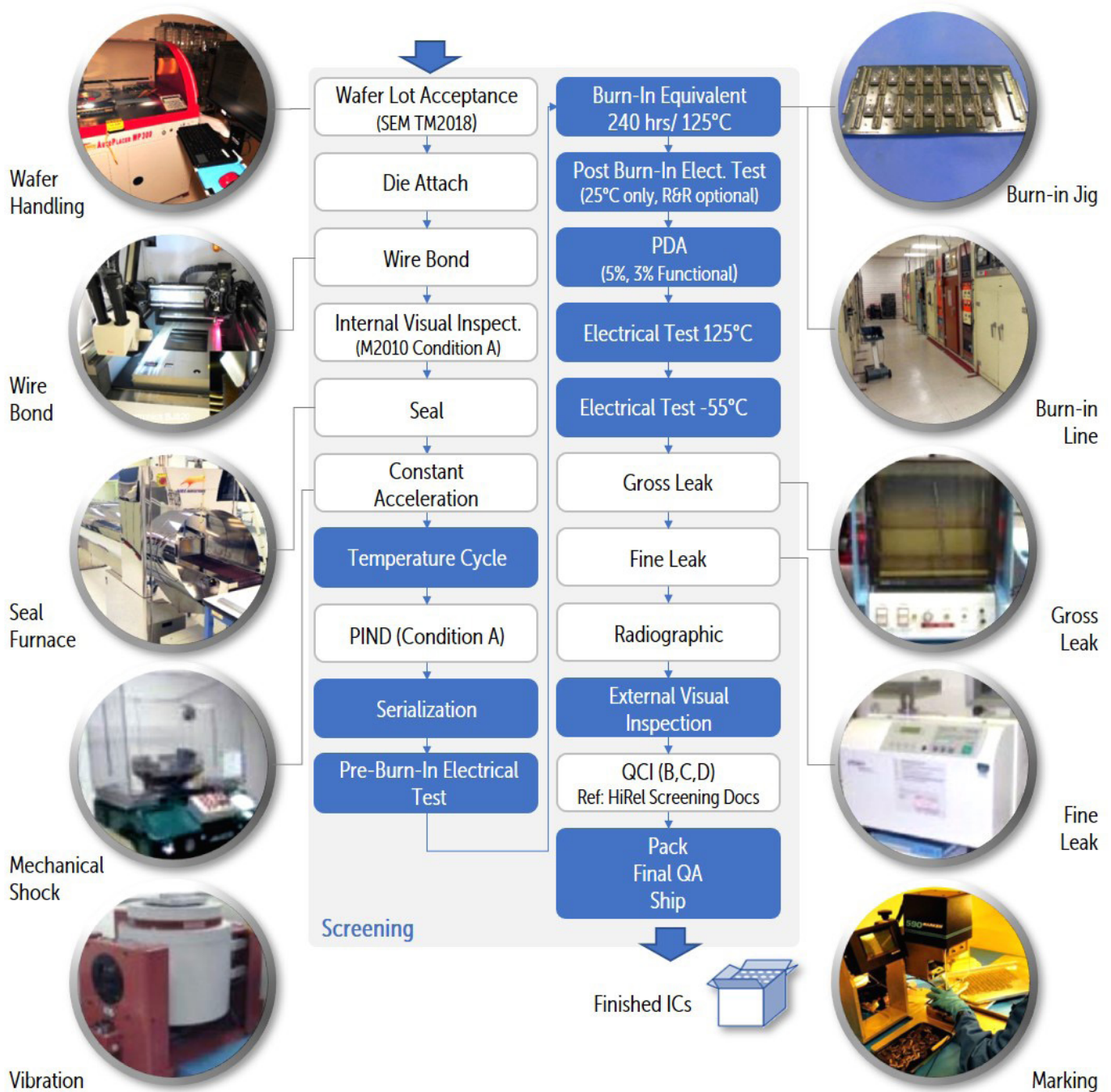

## 4. Off-the-Shelf Catalog Part Types

For military and space applications, HiRel is releasing an ever-increasing number of signal chain, RF, and power devices that are available as catalog parts and ready to go.

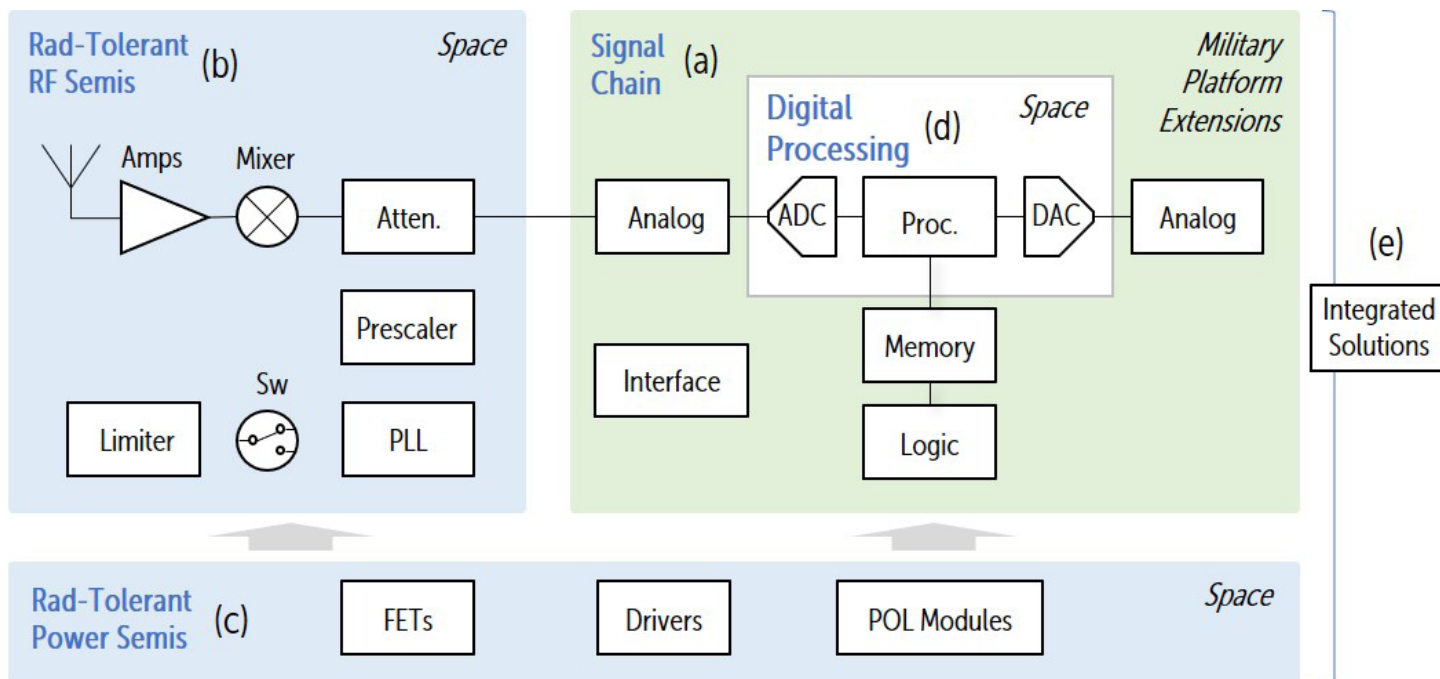

### Military



#### 4(a) Platform Extensions – Banked Parts

One aspect of our business model is a commitment to the continued availability of key military parts. As semiconductor companies gradually exit the market, we buy their legacy inventory and carefully store it away to ensure future supply.

#### Example Device-Types

##### Analog:

- Op-Amps
- Comparators
- Voltage regulators
- Multi-vibrators

##### Interface ICs:

- Bus transceivers
- Line drivers
- Peripheral drivers
- Microprocessor interfaces

##### Logic:

- Standard logic
  - CMOS
  - Bipolar
- Programmable logic

##### Memory:

- CBRAM
- MCM
- DDR
- FIFO
- PROM
- SRAM

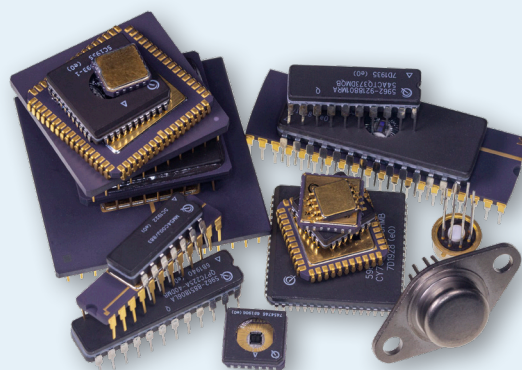

Space Catalog Parts

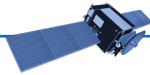

4(b) Radiation Tolerant RF

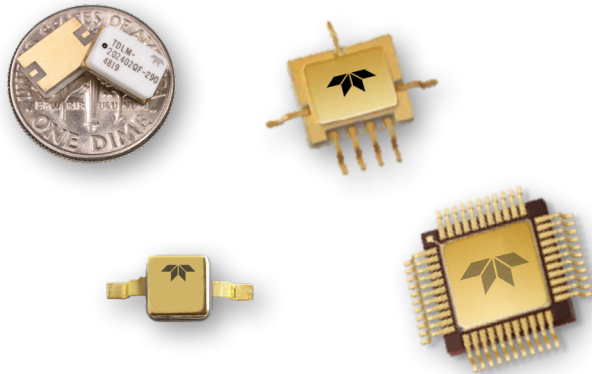

Teledyne e2v HiRel’s standard line of RF and microwave components provides a cost and time effective approach to meet the requirements commonly found in military and space applications.

When system performance or program screening requirements call for more than Teledyne e2v HiRel’s standard catalog parts, we can tailor a solution by taking a standard catalog device, assembling with proven assembly processes and tailoring a custom screening program that can be created by either adding or removing screening options or by generating a custom qualification sequence.

4(c) Radiation Tolerant Power

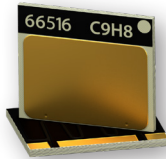

Teledyne e2v HiRel Electronics (HiRel) offers GaN HEMT and Point-of-Load power solutions dedicated to high reliability applications. The leading-edge Gallium Nitride technology in GaN Systems’ solutions enable high power density designs with four times less space requirements. The Peregrine RF based POL products combine outstanding radiation performance with high levels of integration and easy to use features.

4(d) Digital Processing



Teledyne is leading the digitization of space processing with fully qualified DACs, ADCs and processors from Teledyne e2v<sup>[1]</sup>.

In parallel, Teledyne Scientific is a key supplier of data converters to many military platforms<sup>[2]</sup>.

Military & Space



4(e) Integrated Solutions/ Microelectronics

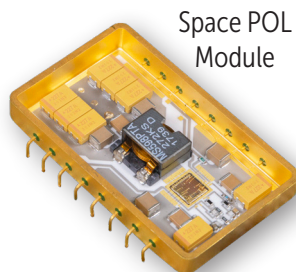

Space POL Module

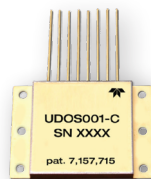

Radiation Dosimeter

At our facility in Lewisburg, TN, we operate as a DOD Trusted Supplier with over 50 years of experience in microelectronics assembly. We provide assembly services for a wide range of microelectronic parts essential to ongoing military programs. We can offer custom advanced manufacturing capabilities including flip chip, wire bonding, underfill, and die stacking for efficient integrated solutions.

We are also able to build Multi-Chip / Hybrid packages combining die and packaged parts into power, RF, signal chain or digital processing modules for defense and space applications.

[1] <https://www.teledynedefenseelectronics.com/e2vrel/Converters%20and%20Processors/Pages/Converters%20%26%20Processors.aspx>

[2] <http://www.teledyne-si.com/products-and-services/scientific-company/data-converters>



## 5. Custom Parts, Resurrections



We specialize in going the extra mile to keep platforms alive. Services include obsolete parts sourcing, repackaging die, building interposers to fit legacy footprints, or even total ground-up resurrections of ICs. Our ability to redesign parts and have new wafers fabricated allows us to provide beyond EoL support.

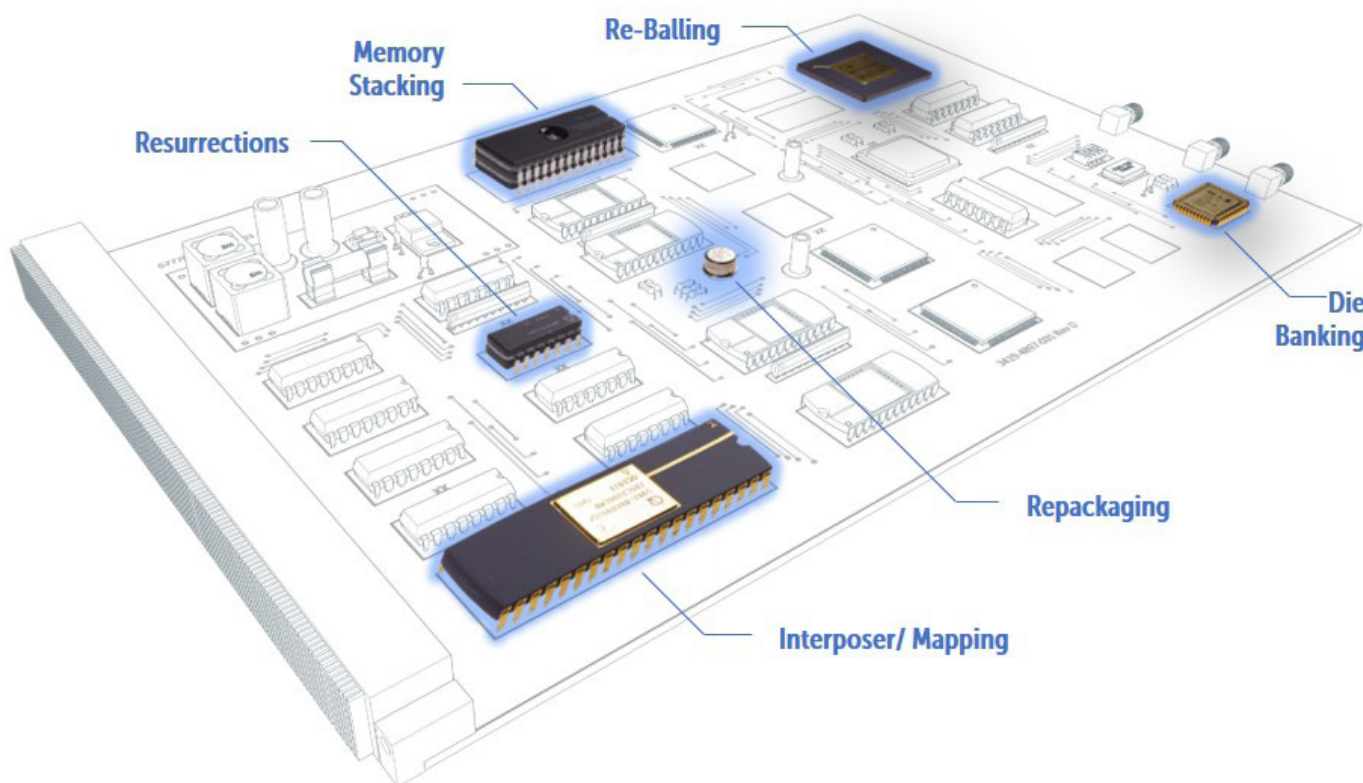

## 6. Customer Qualification & Test Services

The expertise and extensive screening and testing capabilities we've built up can also be applied to customer-furnished wafers and devices.

Recent examples include:

1. A customer with a wafer lot of RF devices needed them packaged, tested, and qualified. We packaged the devices in plastic, created test boards and performed high volume testing at rates of several thousand a month.
2. Another customer had commercial parts that were sitting on their shelf for an extended period of time, and simply wanted us to do sample testing to verify that the components were still good.

We offer a flexible and comprehensive range of services for customer furnished wafers and packaged parts.

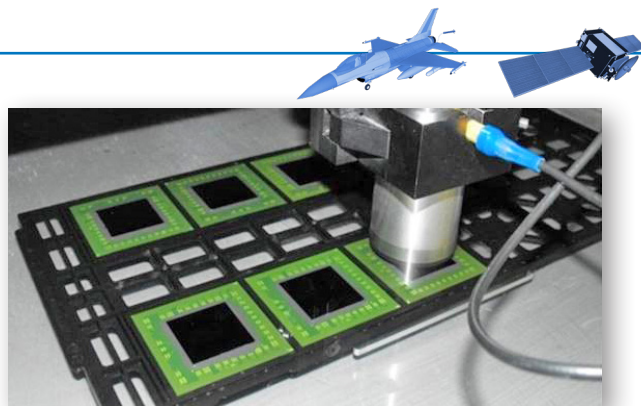
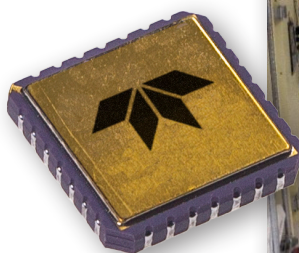

## Global Sales Office

Teledyne e2v HiRel Electronics  
765 Sycamore Drive  
Milpitas, CA 95035 USA  
Tel: +1 (408) 737 0992  
Fax: +1 (408) 736 8708  
[tdemarketing@teledyne.com](mailto:tdemarketing@teledyne.com)

