

HIGH-VIBRATION HIGH-PERFORMANCE TO-5 RELAY DPDT



SERIES	RELAY TYPE
412V	DPDT High-Vibration relay
412DV	DPDT High-Vibration relay, Internal Diode for coil transient suppression

DESCRIPTION

The 412V TO-5 relays, originally conceived and developed by Teledyne, have become the industry standards for low level switching from dry circuit to 1 ampere in high-vibration environments. Designed for high-density PC board mounting, these TO-5 relays are some of the most versatile ultraminiature relay available because of their small size and low coil power dissipation.

The V Series high-vibration relays are designed to withstand vibration levels of 250 to 380 g's at the frequencies noted, when tested on a resonant beam for 10 to 20 seconds, in the axis parallel to contact motion (x-axis). A unique magnetic circuit prevents contact opening (chatter) in excess of 10 microseconds under vibration or shock conditions.

Typical applications:

- Avionics aircraft control
- Aircraft control systems
- Transportation systems (rail/truck)

By virtue of their inherently low intercontact capacitance and contact circuit losses, these TO-5 relays have proven to be excellent ultraminiature RF switches for applications with frequency ranges well into the UHF spectrum. A typical RF application for the TO-5 relay is in handheld radio transceivers, wherein the combined features of good RF performance, small size, low coil power dissipation and high reliability make it a preferred method of Transmit- Receive switching (see Figure 1). RF switches for applications with frequency ranges well into the UHF spectrum.

ENVIRONMENTAL AND PHYSICAL SPECIFICATIONS	
Temperature	-65°C to +125°C
Vibration (Note 1)	250 g's at 140 ±5Hz 350 g's at 170 ±5Hz 380 g's at 200 ±5Hz 100 g's to 1000 Hz 50 g's to 2000 Hz
Shock (Note 1)	75 g's 6ms, half-sine
Acceleration	50 g's
Enclosure	Hermetically Sealed
Weight	412V 0.09 oz. (2.55g) max.

INTERNAL CONSTRUCTION

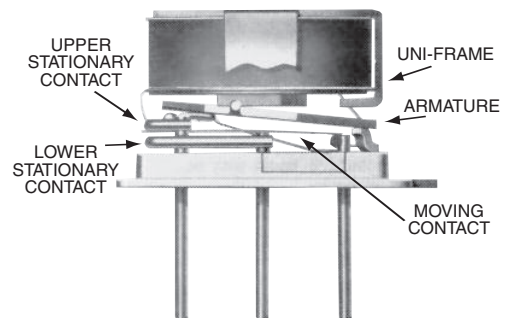

GENERAL ELECTRICAL SPECIFICATIONS (-65°C to +125°C unless otherwise noted)(Notes 2 & 3)

Contact Arrangement	2 Form C (DPDT)	
Rated Duty	Continuous	
Contact Resistance	0.10 Ω max. before life; 0.20 Ω max. after life @ 1A/28Vdc	
Contact Load Rating (DC)	Resistive: 1 A / 28 Vdc Inductive: 200 mA / 28 Vdc (320mH) Lamp: 100 mA / 28 Vdc (320mH) Low level: 10 to 50 μA @ 10 to 50 mV	
Contact Load Rating (AC)	Resistive: 250 mA / 115Vac, 60 and 400 Hz (Case not grounded) 100 mA / 115 Vac, 60 and 400 Hz (Case grounded)	
Contact Life Ratings	10,000,000 cycles (typical) at low level 1,000,000 cycles (typical) at 0.5 A / 28 Vdc resistive 100,000 cycles min. at all other loads specified above	
Contact Overload Rating	2 A / 28 Vdc Resistive (100 cycles min.)	
Coil Operating Power	620 mW typical at nominal rated voltage	
Operate Time	3.0 ms max.	
Contact Carry Rating	Contact Factory	
Release Time	412V	2.0 ms max.
	412DV	4.0 ms max.
Contact Bounce	1.5 ms	
Intercontact Capacitance	0.4 pf typical	
Insulation Resistance	1,000 MΩ min. between mutually isolated terminals	
Dielectric Strength	Atmospheric: 500 (Vrms/60 Hz)	70,000 ft: 125 (Vrms/60 Hz)

Part Numbering System (Notes 5 & 6)

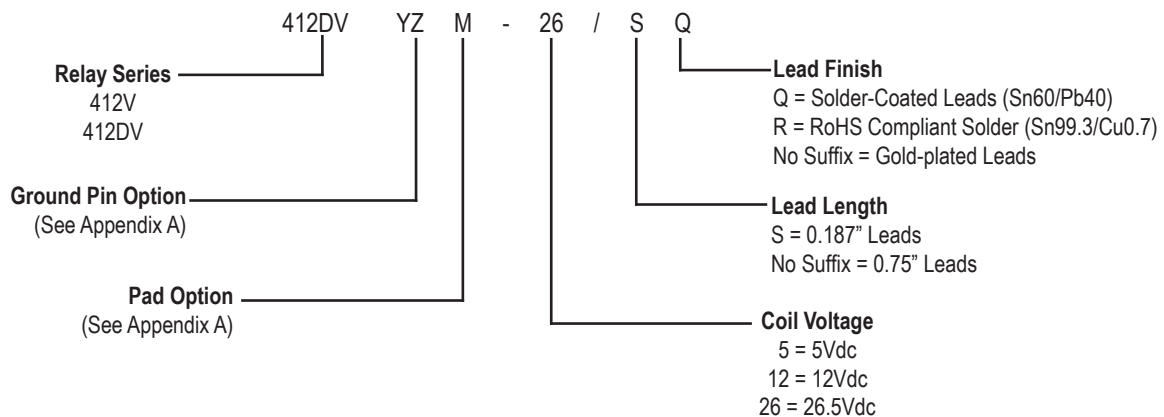

NOTES:

- Relay contacts will exhibit no chatter in excess of 10 μs or transfer in excess of 1 μs.
- "Typical" characteristics are based on available data and are best estimates. No ongoing verification tests are performed.
- Unless otherwise specified, parameters are initial values.
- Measured at nominal voltage for 5 s. maximum.
- Unless otherwise specified, relays will be supplied with gold-plated leads.
- The slash and characters appearing after the slash are not marked on the relay.

DETAILED ELECTRICAL SPECIFICATIONS (-65°C to +125°C unless otherwise noted)(Note 3)

BASE PART NUMBERS (412V)		412V-5 412DV-5	412V-12 412DV-12	412V-26 412DV-26
Coil Voltage	Nom.	5.0	12.0	26.5
	Max.	5.8	16.0	32.0
Drop-Out Voltage (Vdc)	412V 412DV	Min.	0.14	0.89
		Max.	2.3	13.0
Coil Resistance (Ohms ±10%)	412V	50	235	1130
	412DV	33	215	1050
Pick-up Voltage (Vdc, Max.) Pulse Operation		4.7	11.0	22.0

PERFORMANCE CURVES (Note 2)

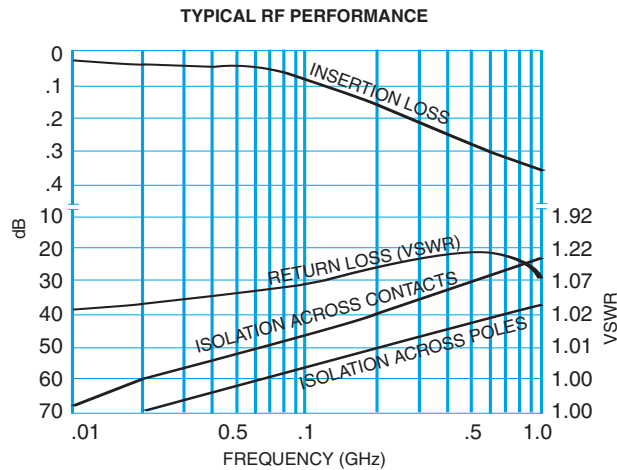

FIGURE 1

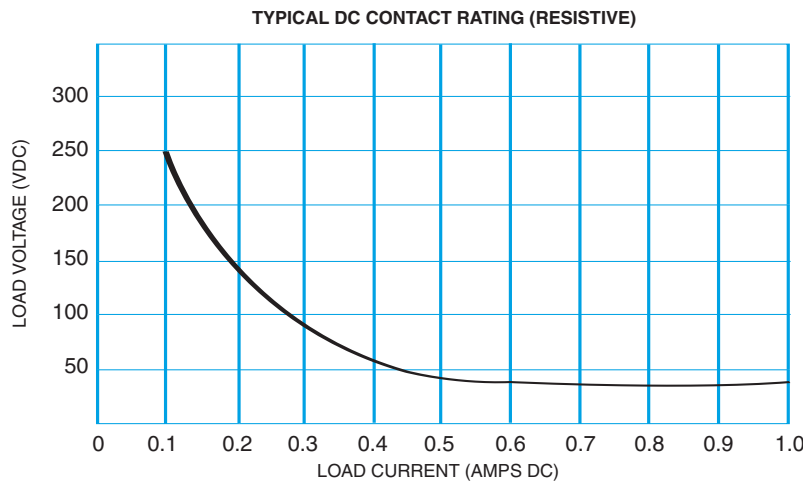
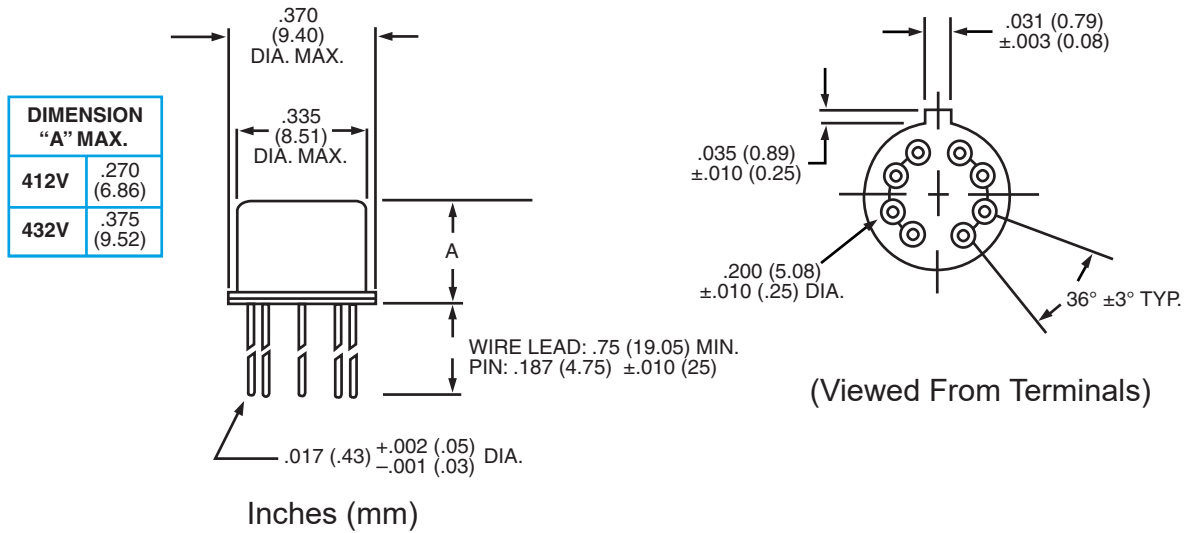
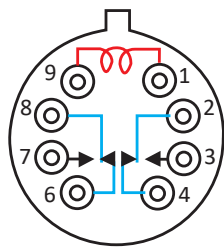

FIGURE 2

OUTLINE DIMENSIONS



SCHEMATIC DIAGRAMS



412V

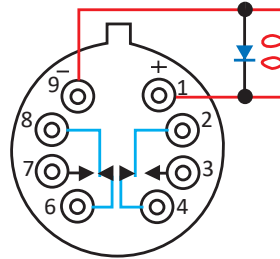

412DV

APPENDIX A : Spacer Pads & Spreader Pads

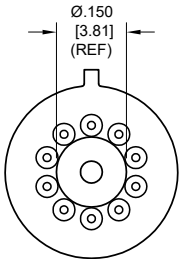
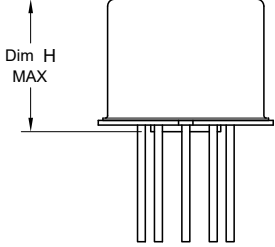
Pad designation and bottom view dimensions	Height	For use with the following:	Dim. H Max.
		ER412, J412	.295 (7.49)
<p>“M4” Spacer Pad for TO-5</p>			
<p>Notes:</p> <ol style="list-style-type: none"> 1. Spacer pad material: Polyester film. 2. To specify an “M4” spacer pad, refer to the part numbering system in the datasheet. 3. Dimensions are in inches (mm). 4. Unless otherwise specified, tolerance is $\pm .010$” (.25 mm). 5. Add 10 mΩ to the contact resistance shown in the datasheet. 6. Add 0.01 oz. (0.25 g) to the weight of the relay assembly shown in the datasheet. 			

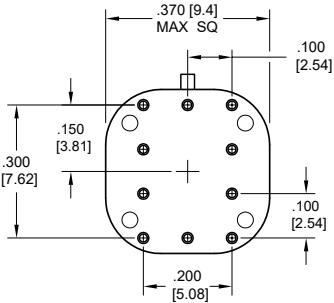
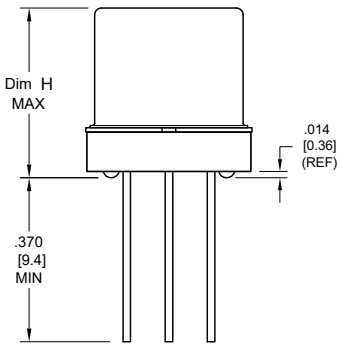
Pad designation and bottom view dimensions	Height	For use with the following:	Dim. H Max.
		ER411T, ER412, J412	.388 (9.86)
<p>“M” Spreader Pad <u>5/</u> <u>6/</u></p>			
<p>Notes:</p> <ol style="list-style-type: none"> 1. Spreader pad material: Diallyl Phthalate. 2. To specify an “M” spreader pad, refer to the mounting variants portion of the part number example in the applicable datasheet. 3. Dimensions are in inches (mm). 4. Unless otherwise specified, tolerance is $\pm .010$” (0.25 mm). <u>5/</u>. Add 25 mΩ to the contact resistance shown in the datasheet. <u>6/</u>. Add .01 oz. (0.25 g) to the weight of the relay assembly shown in the datasheet. 			

APPENDIX A : Ground Pin Positions

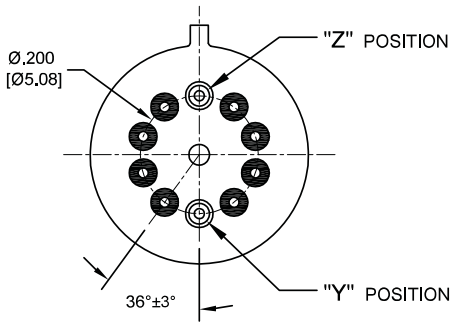

- Indicates ground pin position
- Indicates glass insulated lead position
- ⊙ Indicates ground pin or lead position depending on relay type

TO-5 Relays:

ER412, ER412T, ER422, ER432, ER432T, 712,
712TN, 400H, 400K, 400V, RF300, RF303, RF341,
RF312, RF332, RF310, RF313, RF320, RF323,
SI800, SI803, RF700, RF703

NOTES

1. Terminal views shown
2. Dimensions are in inches (mm)
3. Tolerances: $\pm .010$ ($\pm.25$) unless otherwise specified
4. Ground pin positions are within .015 (0.38) dia. of true position
5. Ground pin head dia., 0.035 (0.89) ref: height 0.010 (0.25) ref.
6. Lead dia. 0.017 (0.43) nom.