

**PART NUMBER DESCRIPTION**

The MMB Series is an ideal solution that consists of Transfer, electromechanical coaxial switches designed to switch a microwave signals in a DPDT configuration. The characteristic impedance is 50 Ohms. The MMB Series is designed to allow the remote operation of 1 to 4 Transfer switches. Remote operation is accomplished via TCP/IP commands to the Matrix's Ethernet interface. Switch control is also accessible via the USB virtual serial port, using the provided command set. Through these interfaces the Coax Switch can be switched to the desired position and its position can be read for verification. The default switch position at power up can be set by the user. The MMB will feature a graphical user interface (GUI), which will enable user to control switches through graphical icons and visuals.



**ENVIRONMENTAL AND PHYSICAL CHARACTERISTICS**

Operating Temperature	-40°C to 65°C
Standard Actuator Life	5,000,000 cycles
Connector Type	SMA, K (2.92 mm), U (2.4 mm)
Weight Enclosure A - SMA Models	
1 Switch	22 oz. (624 g) (max.)
2 Switches	24 oz. (680 g) (max.)
Weight Enclosure B - SMA Models	
2 Switches (N or TNC)	72 oz. (2041 g) (max.)
4 Switches	64 oz. (1814 g) (max.)

**ELECTRICAL CHARACTERISTICS (SWITCHES ONLY)**

RF Contacts	Break before make
Frequency Range	Up to DC-52GHz
Characteristic Impedance	50 Ohms
Terminations	50Ω, 2 Watts CW max
Operate Time	15 ms (max.)
Release Time	15 ms (max.)
Actuation Voltage	24 Vdc
Actuation Current, max. @ ambient	Varies
Magnetic Sensitivity	5 Gauss, 0.5 inch max

**ADDITIONAL INFORMATION**

Interface	USB or TCP/IP
Host Operating System	Windows, MAC, Linux
Operating System	Embedded

**INCLUDED ITEMS**

• AC/DC Power Adapter	• USB Cable
• Power Cord	• Installation CD
• Ethernet Cable	

**BUILD YOUR BOX**

**Number of Switches (Select One):**

ENCLOSURE A	ENCLOSURE B
<input type="checkbox"/> 1	<input type="checkbox"/> 4
<input type="checkbox"/> 2	

**Connector (Select One):**

<input type="checkbox"/> SMA (DC-18GHz)	<input type="checkbox"/> SMA (DC-26.5GHz)
<input type="checkbox"/> K (DC-40GHz)	<input type="checkbox"/> U (DC-52GHz)

**Actuation Type:**

<input type="checkbox"/> Failsafe
-----------------------------------

**Remote Control:**

<input type="checkbox"/> USB & Ethernet
---

**Switch Type:**

<input type="checkbox"/> Transfer
-----------------------------------

Please scan the QR code below and fill out the Mini Matrix Application form. Email the complete form to [relays@teledyne.com](mailto:relays@teledyne.com)



**For additional options, please contact factory.**

# Miniature Matrix: MMB Series Controlled with USB or Ethernet



## BLOCK DIAGRAM EXAMPLE

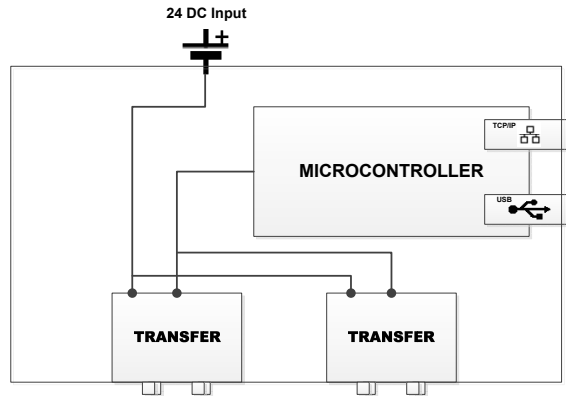

## MECHANICAL OUTLINE FOR ENCLOSURE A

Max. Length with Switches= 7.75 (196.85)

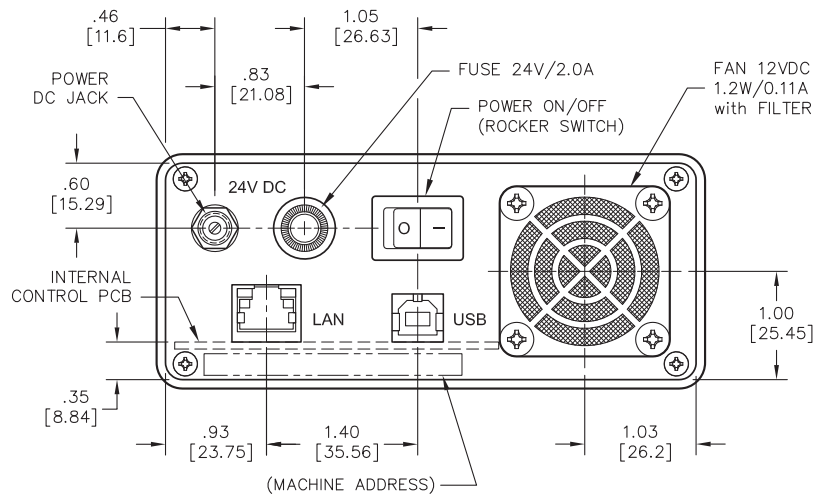

### Enclosure A: UP TO 2 TRANSFER SWITCHES

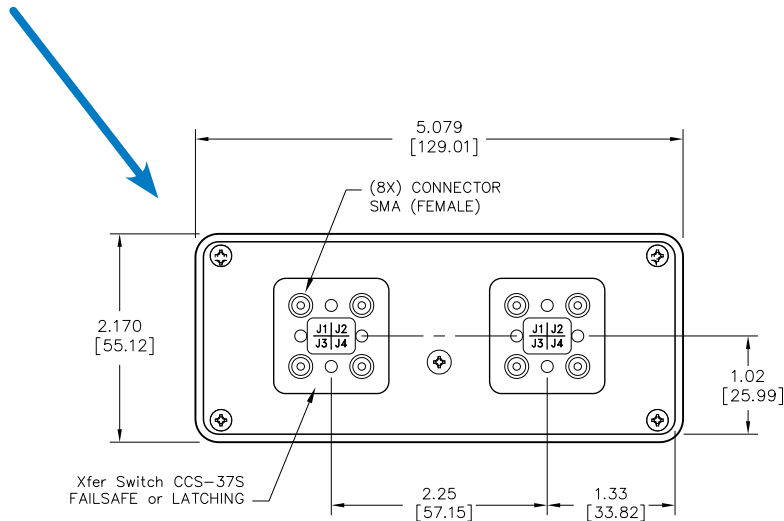

**MECHANICAL OUTLINE FOR ENCLOSURE B**

**Enclosure B: UP TO 4 TRANSFER SWITCHES**

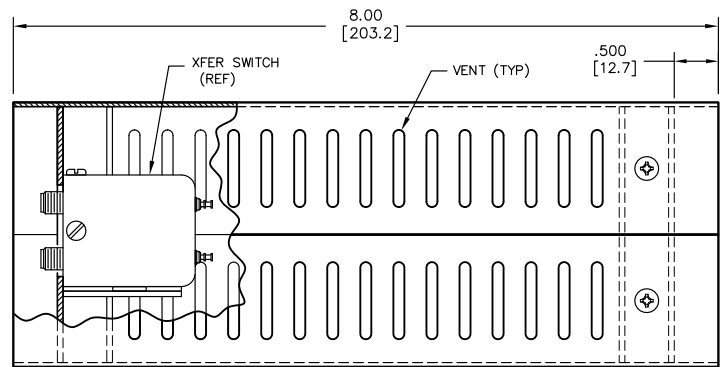
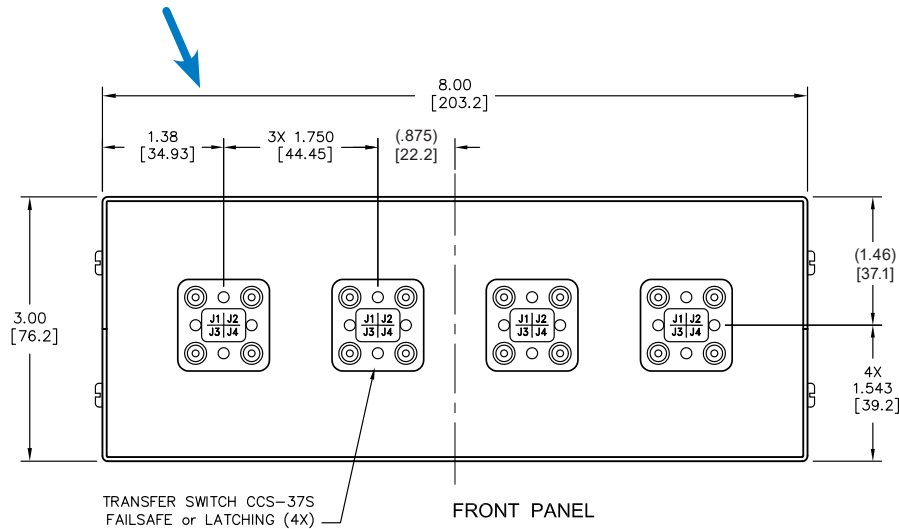

SIDE VIEW

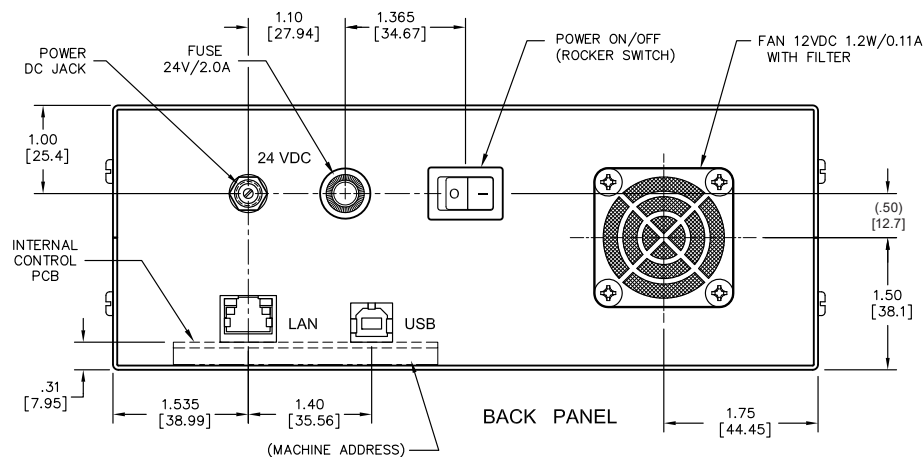

# Miniature Matrix: MMB Series Controlled with USB or Ethernet



## Enclosure B: UP TO 4 2P3T SWITCHES

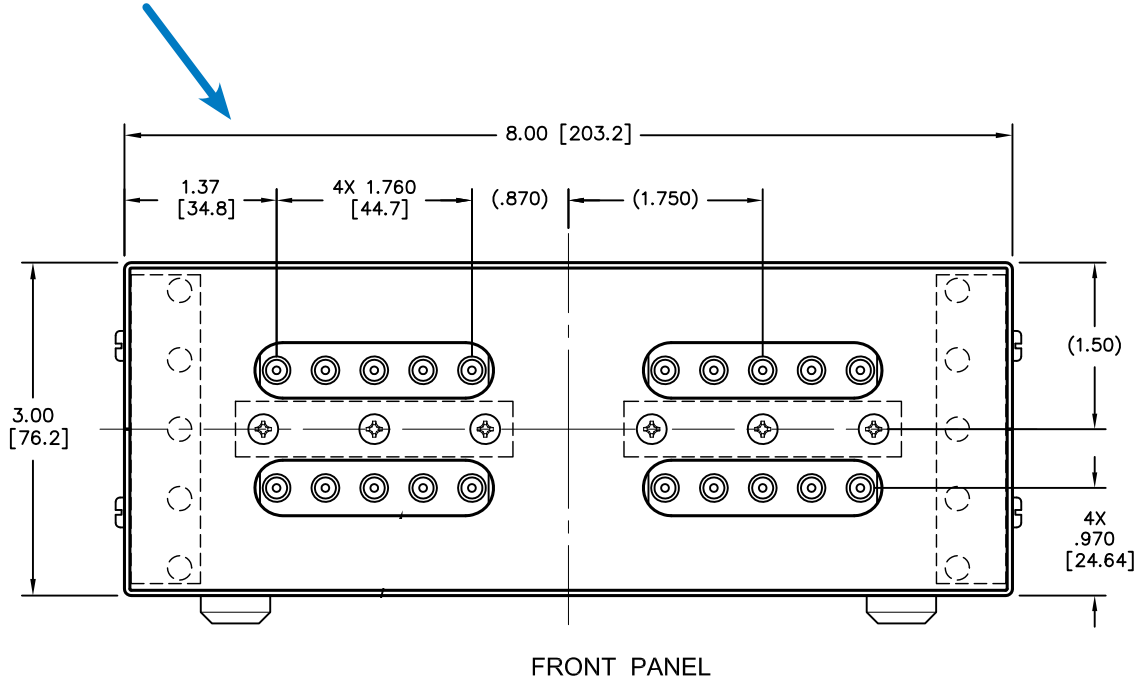

## Enclosure B: UP TO 2 TYPE N CONNECTOR TRANSFER SWITCHES

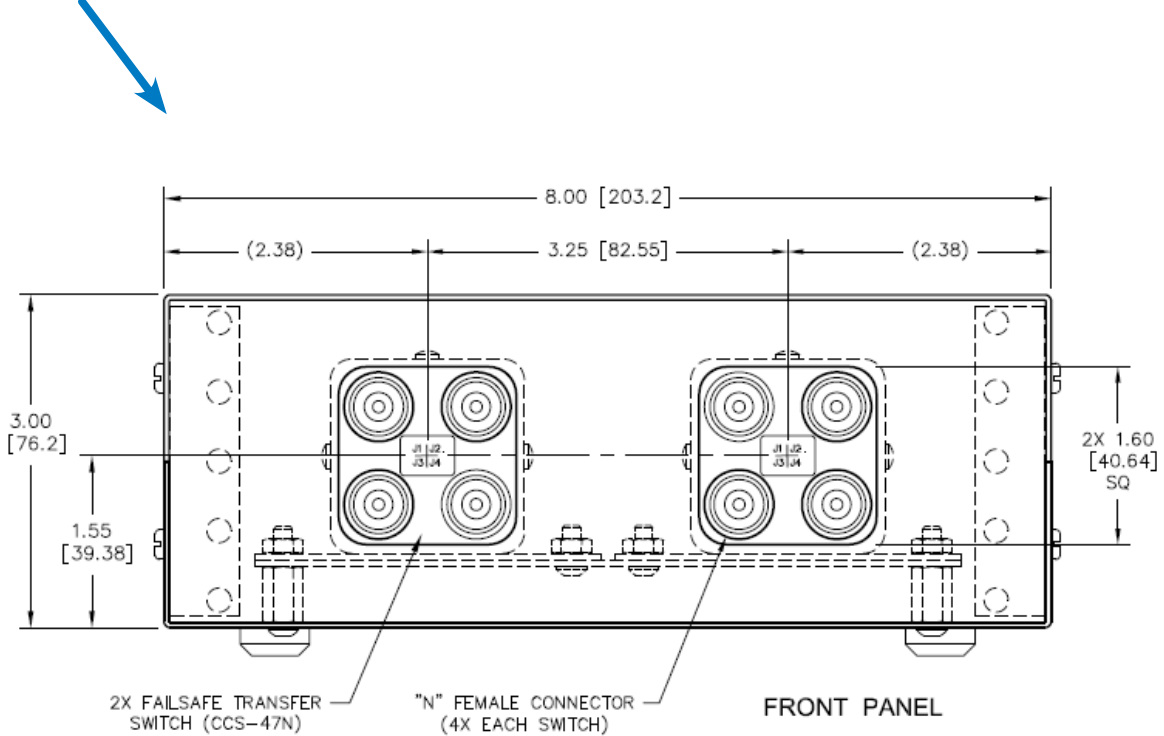

### GLOSSARY

#### Actuator

An actuator is the electromechanical mechanism that transfers the RF contacts from one position to another upon DC command.

#### Arc Suppression Diode

A diode is connected in parallel with the coil. This diode limits the “reverse EMF spike” generated when the coil de-energizes to 0.7 volts. The diode cathode is connected to the positive side of the coil and the anode is connected to the negative side.

#### Date Code

All switches are marked with either a unique serial number or a date code. Date codes are in accordance with MIL-STD-1285 Paragraph 5.2.5 and consist of four digits. The first two digits define the year and the last two digits define the week of the year (YYWW). Thus, 1032 identifies switches that passed through final inspection during the 32nd week of 2010.

#### Fail-safe

A fail-safe switch reverts to the default or fail-safe position when actuating voltage is removed. This is realized by a return spring within the drive mechanism. This type of switch requires the continuous application of operating voltage to select and hold any position. (Multi-position switches are normally open with no voltage applied).

#### Latching

A latching switch remains in the selected position whether or not voltage is maintained. This can be accomplished with either a magnetic or mechanical latching mechanism.

#### Indicator

Indicators tell the system which position the switch is in. Other names for indicators are telemetry contacts or tell back circuit. Indicators are usually a set of internally mounted DC contacts linked to the actuator. They can be wired to digital input lines, status lights, or interlocks. Unless otherwise specified, the maximum indicator contact rating is 30 Vdc, 50 mA, or 1.5 Watts into a resistive load.

#### Internal Termination

Unselected ports are internally terminated to a matched load. The load is 50Ω resistive device. The max RF power rating is 2 Watts CW. Without the internal termination option, the unselected ports are open circuits.

#### Isolation

Isolation is the measure of the power level at the output connector of an unconnected RF channel as referenced to the power at the input connector. It is specified in dB below the input power level.

#### Self-Cutoff

The self-cutoff option disables the actuator current on completion of actuation. Either a series contact (linked to the actuator) or an IC driver circuit provides the current cutoff. This option results in minimum power consumption by the RF switch. Cutthroat is another name used in the industry for this option. Pulse latching is a term used to describe a switch without this feature.

#### SPDT Switch

A single-pole-double-throw, has one input and two output ports.

#### Switching Time

Switching time is the total interval beginning with the arrival of the leading edge of the command pulse at the switch DC input and ending with the completion of the switch transfer, including contact bounce. It consists of three parts: (1) inductive delay in the coil, (2) transfer time of the physical movement of the contacts, and (3) the bounce time of the RF contacts.

#### TTL Switch Driver Option

As a special option, switch drivers can be provided for both fail-safe and latching switches, which are compatible with industry-standard low-power Schottky TTL circuits.

#### Performance Parameters vs Frequency

Generally speaking, the RF performance of coaxial switches is frequency dependent. With increasing frequency, VSWR and insertion loss increase while isolation decreases.

All data sheets specify these three parameters as “worst case” at the highest operating frequency. If the switch is to be used over a narrow frequency band, better performance can be achieved.

#### Actuator Current vs Temperature

The resistance of the actuator coil varies as a function of temperature. There is an inverse relationship between the operating temperature of the switch and the actuator drive current. For switches operating at 28 VDC, the approximate actuator drive current at temperature, T, can be calculated using the equation:

$$I_T = \frac{I_A}{[1 + .00385 (T-20)]}$$

Where:

$I_T$  = Actuator current at temperature, T

$I_A$  = Room temperature actuator current – see data sheet

T = Temperature of interest in °C

#### Magnetic Sensitivity

An electromechanical switch can be sensitive to ferrous materials and external magnetic fields. Neighboring ferrous materials should be permitted no closer than 0.5 inches and adjacent external magnetic fields should be limited to a flux density of less than 5 Gauss.