

PARTNUMBER	DESCRIPTION
CCT-48K	Commercial, Normally Open, Multi-throw, DC-40 GHz
CT-48K	Elite, Normally Open, Multi-throw, DC-40 GHz

The CCT-48K/CT-48K is an internally terminated, broadband, multi-throw, electromechanical coaxial switch designed to switch a microwave signal from a common input to any of 3, 4, 6, or 8 outputs. The characteristic impedance is 50 Ohms. Internal terminations provide an impedance match for the unselected ports. The switches are small using the popular connector spacing on a 1.062" dia. circle. Each position has an individual actuator mechanism allowing random position selection which also minimizes switching time. The CCT-48K/CT-48K comes with a normally open actuator with all ports terminated in 50 Ohms, except the common input port which is open when the switch is de-energized.



ENVIRONMENTAL AND PHYSICAL CHARACTERISTICS	
Storage Temperature	-55°C to 90°C
Operating Temperature	
CCT-48K	-25°C to 65°C
CT-48K ¹	-55°C to 85°C
CT-48K w/ indicator contacts	-45°C to 85°C
Vibration ² , 10 ~ 2000 Hz, 300 s MIL-STD-202 Method 204, Condition C	10 G peak
Shock, Half-Sine Pulse MIL-STD-202 Method 213, Condition D	500 G peak
Moisture Resistance ³	95% RH Non-condensing
Mechanical Life	5,000,000 cycles (min)
Mechanical Life w/ Additional Features	1,000,000 cycles (min)
Connector Type	2.92mm (K)
Weight	SP3T-SP6T 3.7 oz. (105g) approx. SP8T 12 oz. (340g) approx.

1. -40°C to 85°C for Elite SP8T models with Ind or TTL option
2. Non-operating
3. When moisture seal option is selected

ELECTRICAL CHARACTERISTICS	
RF Contacts	Break before make
Frequency Range	DC-40 GHz
Characteristic Impedance	50 Ω
Terminations	50Ω, 2 Watts CW max.
Operate Time	15 ms (max.)
Release Time	15 ms (max.)
Actuation Voltage Available	12 15 24 28 V
Actuation Current, max. @ ambient	420 350 250 200 mA
TTL/Decoders Voltage/Current ¹	
Low Level (Logic 0)	0.0 ~ 0.7 V / 3.2 mA Max at 0.7 V
High Level (Logic 1)	2.4 ~ 5.5 V / 80 μA Max at 2.4 V
Indicator Contact Rating ²	30 Vdc, 50 mA max
Magnetic Sensitivity	5 Gauss, 0.5 inch max

1. For switches with TTL driver or decoder
2. For switches with indicator

PERFORMANCE CHARACTERISTICS FOR SP3T-SP6T MODELS						
Frequency	DC-6 GHz	6-12 GHz	12-18 GHz	18-26.5 GHz	26.5-32 GHz	32-40 GHz
Insertion Loss, (max)	0.20 dB	0.30 dB	0.60 dB	0.80 dB	0.80 dB	1.40 dB
Isolation, (min)	80 dB	75 dB	70 dB	70 dB	60 dB	60 dB
VSWR, (max)	1.25:1	1.30:1	1.60:1	1.70:1	1.80:1	1.95:1

Please see charts on page 7.

PERFORMANCE CHARACTERISTICS FOR SP8T MODELS						
Frequency	DC-6 GHz	6-12 GHz	12-18 GHz	18-26.5 GHz	26.5-32 GHz	32-40 GHz
Insertion Loss, (max.)	0.30 dB	0.40 dB	0.60 dB	0.80 dB	1.50 dB	1.50 dB
Isolation, (min.)	80 dB	70 dB	70 dB	70 dB	70 dB	70 dB
VSWR, (max.)	1.20:1	1.30:1	1.50:1	2.00:1	2.20:1	2.20:1

Please see charts on page 8.

PART NUMBERING SYSTEM

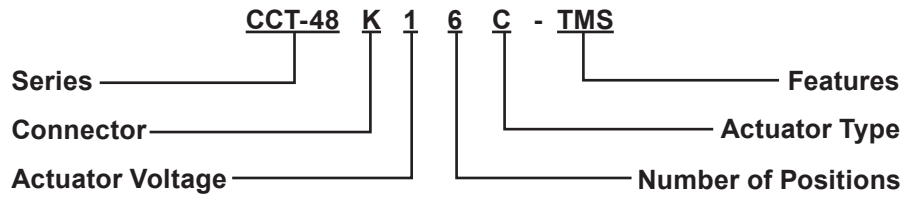

1. Series
 CCR-48 : Commerical, Operating Temp (-25°C to 65°C)
 CR-48 : Elite, Operating Temp (-55°C to 85°C)

4. Number of Positions
 3 : SP3T
 4 : SP4T
 6 : SP6T
 8 : SP8T¹

2. Connector
 K : 2.92 mm Female

5. Actuator Types
 0 : Standard
 C : Indicator Contacts

3. Actuator Voltages
 1 : 28 Vdc Normally Open
 2 : 15 Vdc Normally Open
 3 : 12 Vdc Normally Open
 4 : 24 Vdc Normally Open

6. Features
 T : TTL Driver with Diodes
 D : Transient Suppression & Polarity Protection Diodes
 R : Positive + Common
 TD: TTL Driver with Decoder and Diodes
 M : Moisture Resistant
 S : D-Sub Connector (Male)²



1. SP8T Models will come with D-sub connectors as the standard control interface. For turret style terminals, please contact factory.
 2. D-Sub Connector may be 9, 15, or 26 pin depending on number of throws. (See Connector Pinout page)

For additional options, please contact factory.

SCHEMATICS AND MECHANICAL OUTLINE FOR SP3T, SP4T, AND SP6T

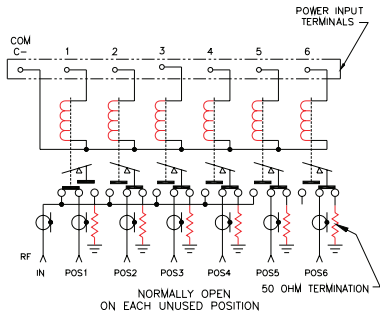

Analog

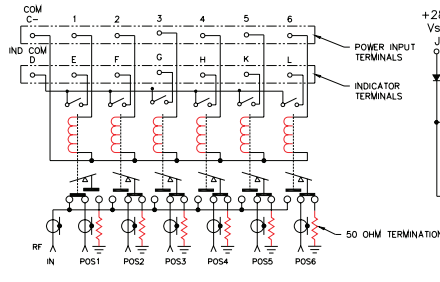

Indicators

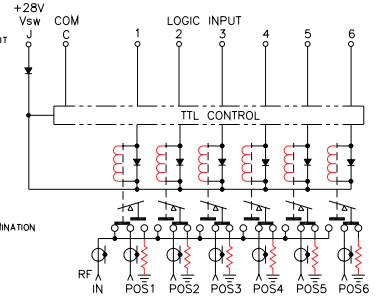

TTL

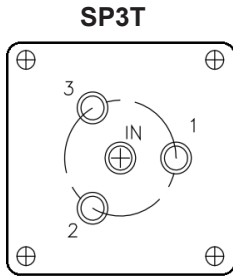

SP3T

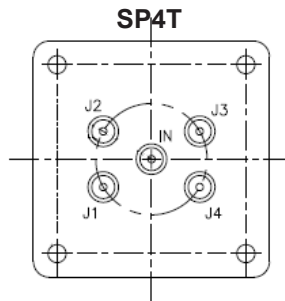

SP4T

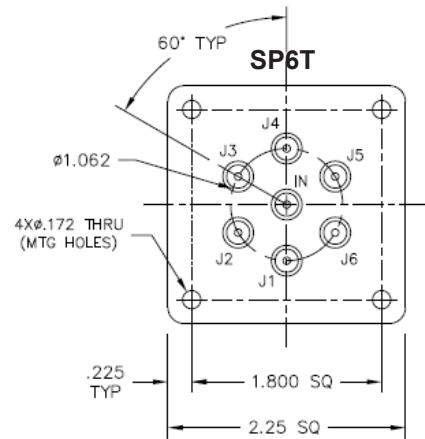

SP6T

All Models will have a 2.52 max Height
- Contact factory for additional model outlines

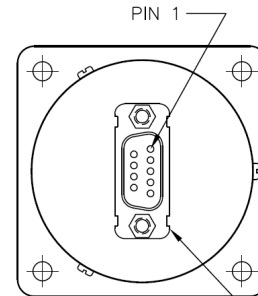
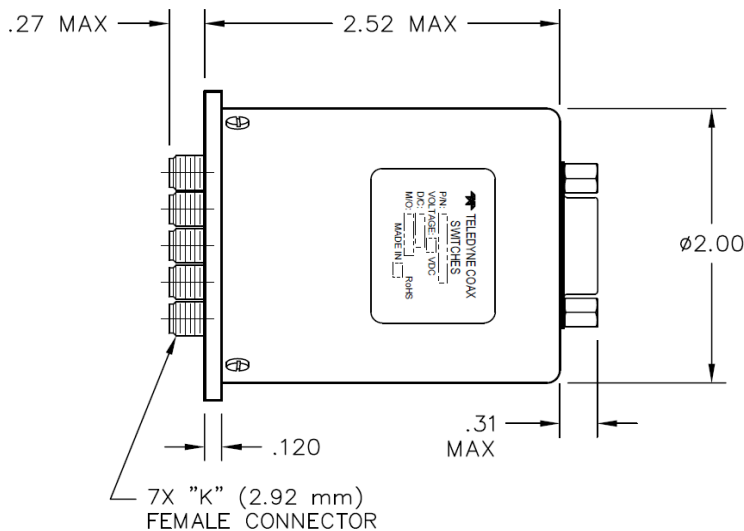

D-Sub
9-PIN D-SUB MINI CONNECTOR

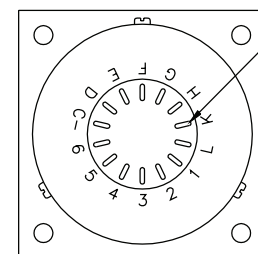

Standard

14X SOLDER TERMINALS
SOLDER WIRE MAXIMUM
TEMP 250°C FOR NO
MORE THAN 5 SEC

SCHEMATICS AND MECHANICAL OUTLINE FOR SP8T

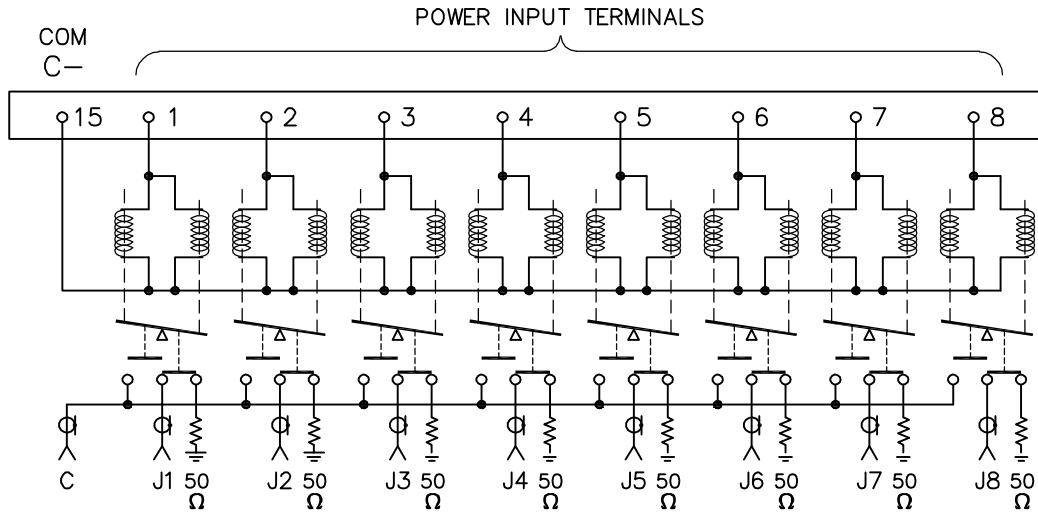

SP8T Failsafe (N.O.) - Terminated

*Height H will change based on options selected
 H = 2.52 max for Standard, Indicator, D-Sub, and +Positive COM models
 H = 3.20 max for all other model combinations
 - Contact factory for additional model outlines

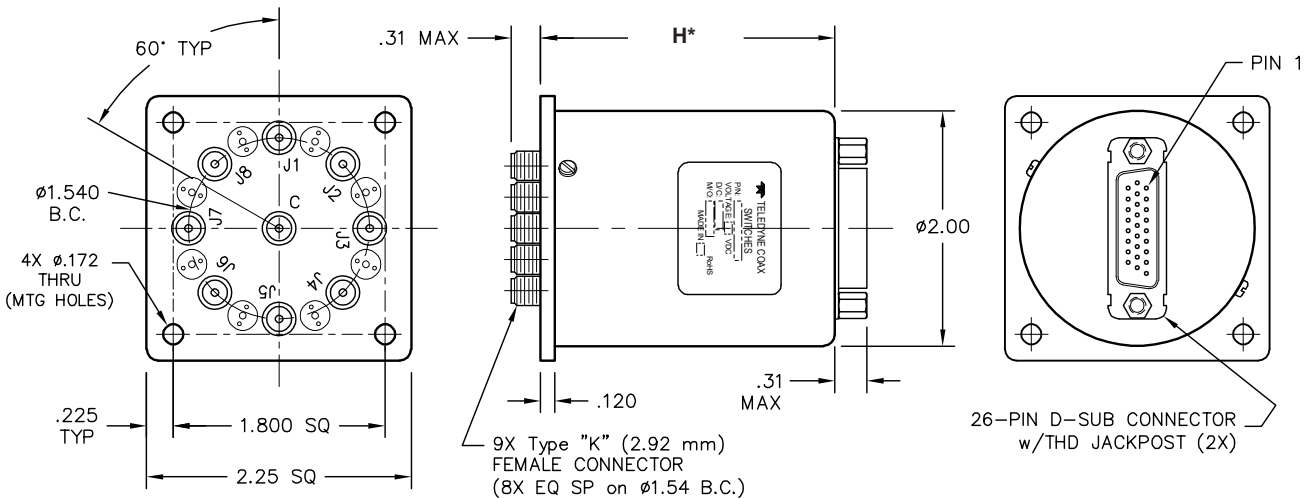

TRUTH TABLE & PINOUT FOR SP3T, SP4T & SP6T

TTL DECODER TRUTH TABLE								
LOGIC INPUT			RF POSITION					
Logic 1	Logic 2	Logic 3	J1	J2	J3	J4	J5	J6
0	0	0	ON	OFF	OFF	OFF	OFF	OFF
1	0	0	OFF	ON	OFF	OFF	OFF	OFF
0	1	0	OFF	OFF	ON	OFF	OFF	OFF
1	1	0	OFF	OFF	OFF	ON	OFF	OFF
0	0	1	OFF	OFF	OFF	OFF	ON	OFF
1	0	1	OFF	OFF	OFF	OFF	OFF	ON
1	1	1	ALL COILS OFF					

9-PIN (DA-9) OR 15-PIN (DA-15) D-SUB PINOUT						
OPTIONS						
Pin No.	BASIC	INDICATOR	TTL	INDICATOR & TTL	TTL + DECODERS	INDICATOR & TTL + DECODER
1	POS 1	POS 1	TTL 1	TTL 1	LOGIC 1	LOGIC 1
2	POS 2	POS 2	TTL 2	TTL 2	LOGIC 2	LOGIC 2
3	POS 3	POS 3	TTL 3	TTL 3	LOGIC 3	LOGIC 3
4	POS 4	POS 4	TTL 4	TTL 4		
5	POS 5	POS 5	TTL 5	TTL 5		
6	POS 6	POS 6	TTL 6	TTL 6		
7	COM (C)	COM (C)	COM (C)	COM (C)	COM (C)	COM (C)
8			VSW (J)	VSW (J)	VSW (J)	VSW (J)
9		IND COM (D)		IND COM (D)		IND COM (D)
10		IND 1 (E)		IND 1 (E)		IND 1 (E)
11		IND 2 (F)		IND 2 (F)		IND 2 (F)
12		IND 3 (G)		IND 3 (G)		IND 3 (G)
13		IND 4 (H)		IND 4 (H)		IND 4 (H)
14		IND 5 (K)		IND 5 (K)		IND 5 (K)
15		IND 6 (L)		IND 6 (L)		IND 6 (L)

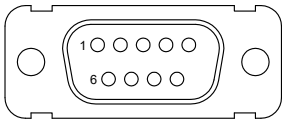

9-PIN D-SUB CONNECTOR

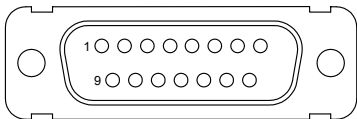

15-PIN D-SUB CONNECTOR

“-S option” 9-pin, 15-pin connector
(Example: CCT-48K660-S)

TRUTH TABLE & PINOUT FOR SP8T

TTL DECODER TRUTH TABLE											
LOGIC INPUT				RF POSITION							
Logic 1	Logic 2	Logic 3	Logic 4	J1	J2	J3	J4	J5	J6	J7	J8
0	0	0	0	ON	OFF	OFF	OFF	OFF	OFF	OFF	OFF
1	0	0	0	OFF	ON	OFF	OFF	OFF	OFF	OFF	OFF
0	1	0	0	OFF	OFF	ON	OFF	OFF	OFF	OFF	OFF
1	1	0	0	OFF	OFF	OFF	ON	OFF	OFF	OFF	OFF
0	0	1	0	OFF	OFF	OFF	OFF	ON	OFF	OFF	OFF
1	0	1	0	OFF	OFF	OFF	OFF	OFF	ON	OFF	OFF
0	1	1	0	OFF	OFF	OFF	OFF	OFF	OFF	ON	OFF
1	1	1	0	OFF	OFF	OFF	OFF	OFF	OFF	OFF	ON
1	1	1	1	ALL COILS OFF							

26-PIN (DA-26) D-SUB PINOUT						
OPTIONS						
Pin No.	BASIC	INDICATOR	TTL	INDICATOR & TTL	TTL + DECODERS	INDICATOR & TTL + DECODER
1	POS 1	POS 1	TTL 1	TTL 1	LOGIC 1	LOGIC 1
2	POS 2	POS 2	TTL 2	TTL 2	LOGIC 2	LOGIC 2
3	POS 3	POS 3	TTL 3	TTL 3	LOGIC 3	LOGIC 3
4	POS 4	POS 4	TTL 4	TTL 4	LOGIC 4	LOGIC 4
5	POS 5	POS 5	TTL 5	TTL 5		
6	POS 6	POS 6	TTL 6	TTL 6		
7	POS 7	POS 7	TTL 7	TTL 7		
8	POS 8	POS 8	TTL 8	TTL 8		
9						
10						
11			VSW (J)	VSW (J)	VSW (J)	VSW (J)
12						
13	COM (C)	COM (C)	COM (C)	COM (C)	COM (C)	COM (C)
14						
15		IND COM (D)		IND COM (D)		IND COM (D)
16		IND 1 (E)		IND 1 (E)		IND 1 (E)
17		IND 2 (F)		IND 2 (F)		IND 2 (F)
18		IND 3 (G)		IND 3 (G)		IND 3 (G)
19		IND 4 (H)		IND 4 (H)		IND 4 (H)
20		IND 5 (K)		IND 5 (K)		IND 5 (K)
21		IND 6 (L)		IND 6 (L)		IND 6 (L)
22		IND 7 (M)		IND 7 (M)		IND 7 (M)
23		IND 8 (N)		IND 8 (N)		IND 8 (N)
24						
25						
26						

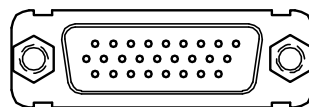

26-PIN D-SUB CONNECTOR

RF PERFORMANCE CURVES FOR SP3T - SP6T MODELS

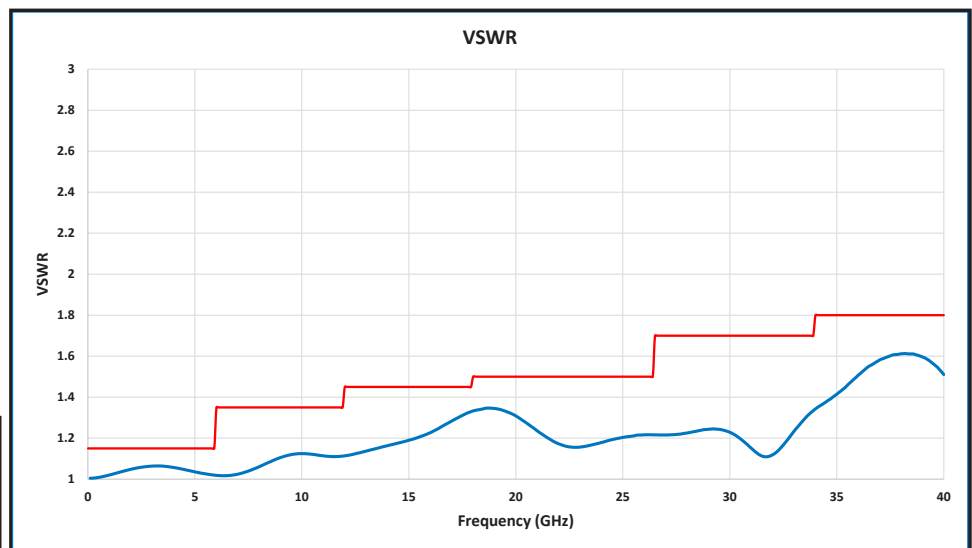
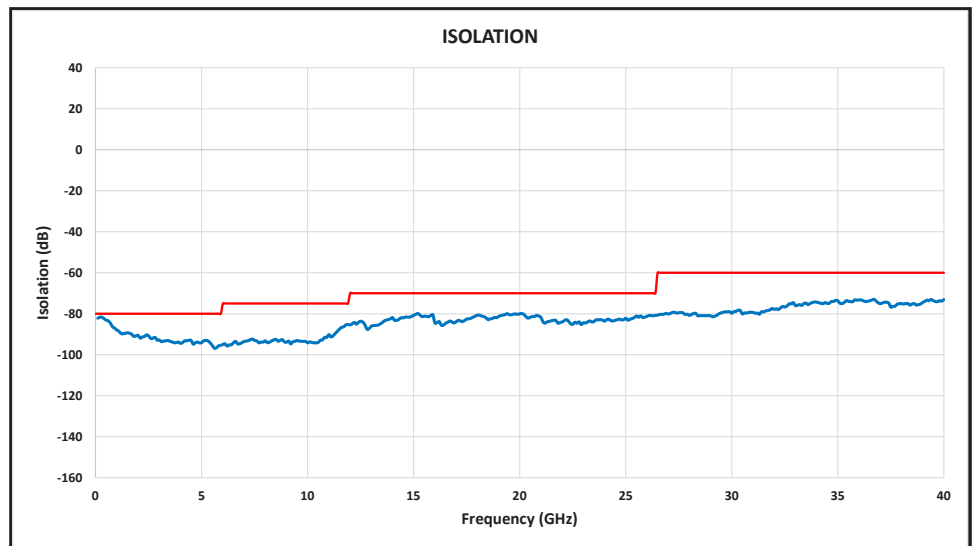
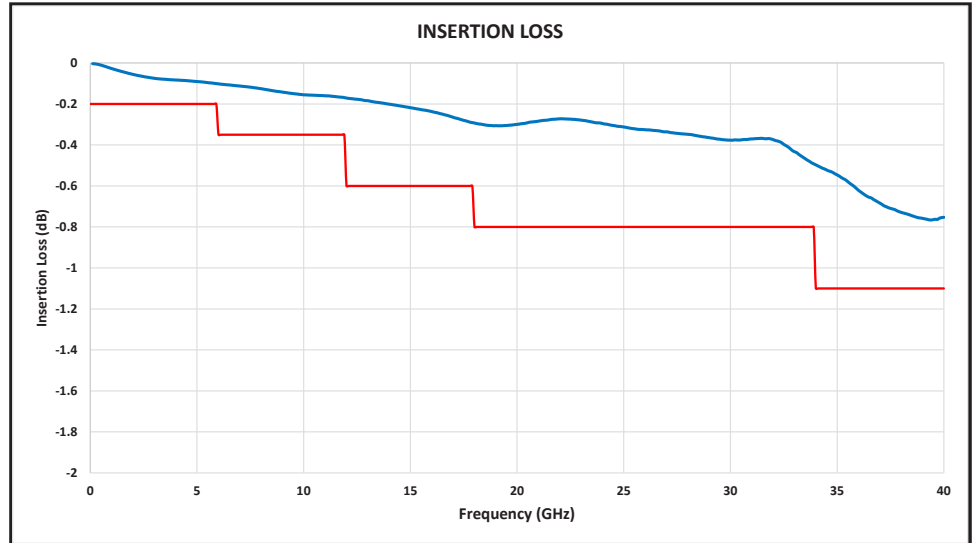

— TYPICAL
 — MAXIMUM TEST LIMIT

RF PERFORMANCE CURVES FOR SP8T MODEL

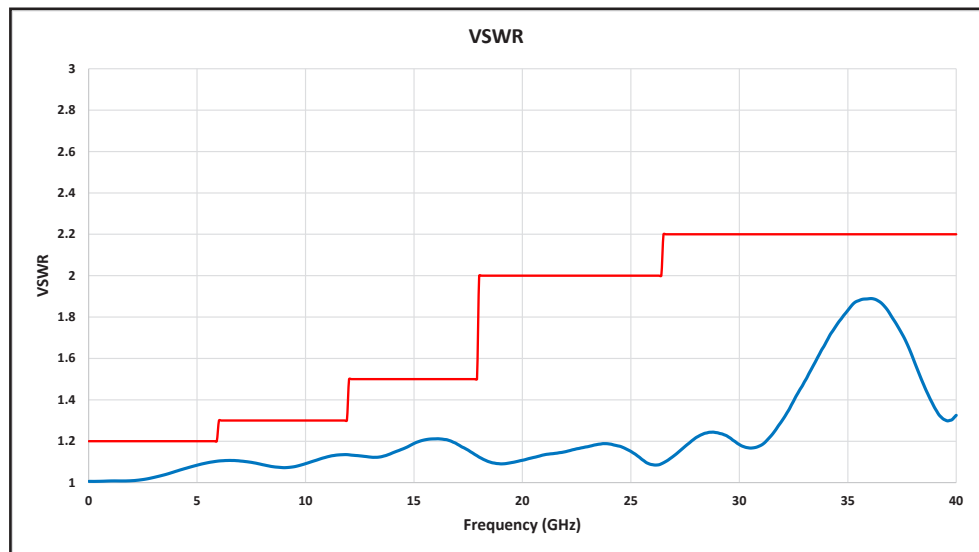
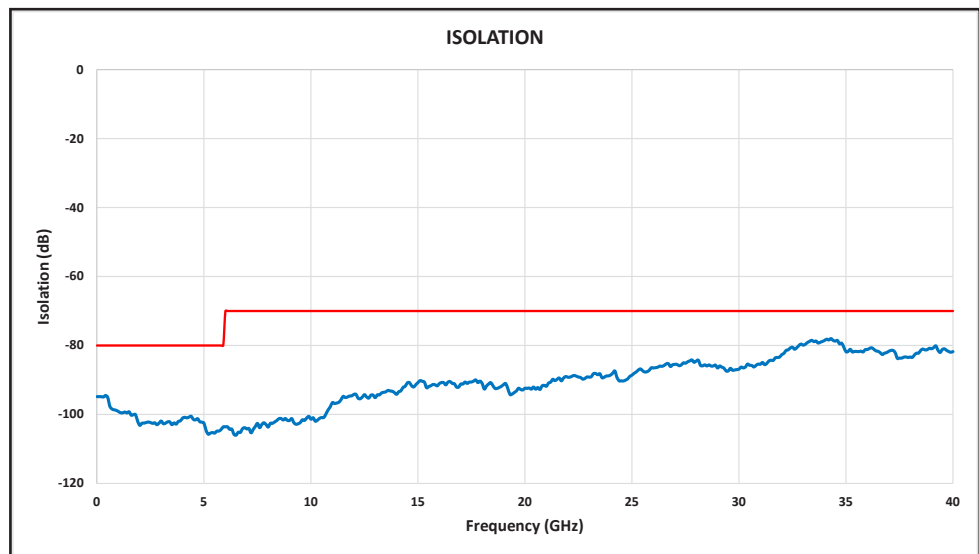
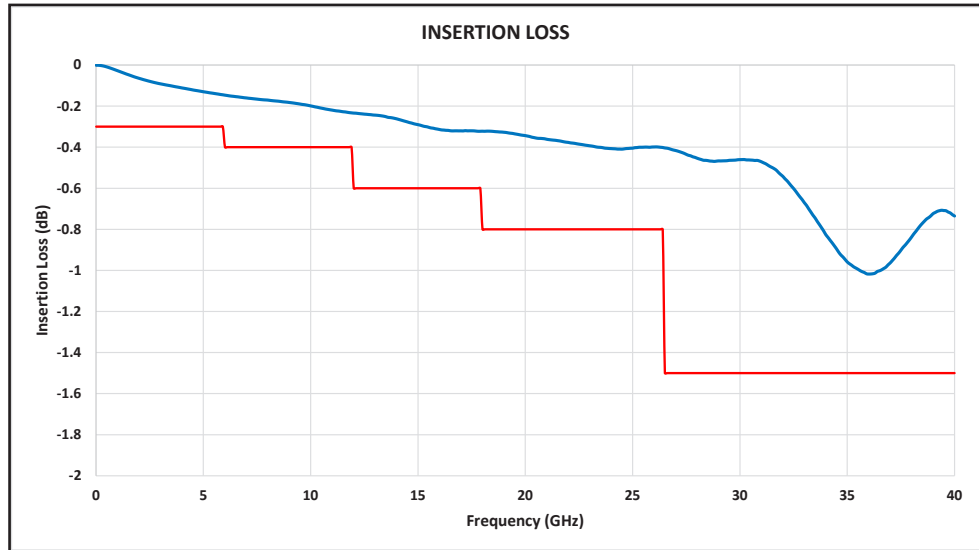

— TYPICAL
 — MAXIMUM TEST LIMIT

TYPICAL POWER PERFORMANCE CURVE

Power Handling vs. Frequency

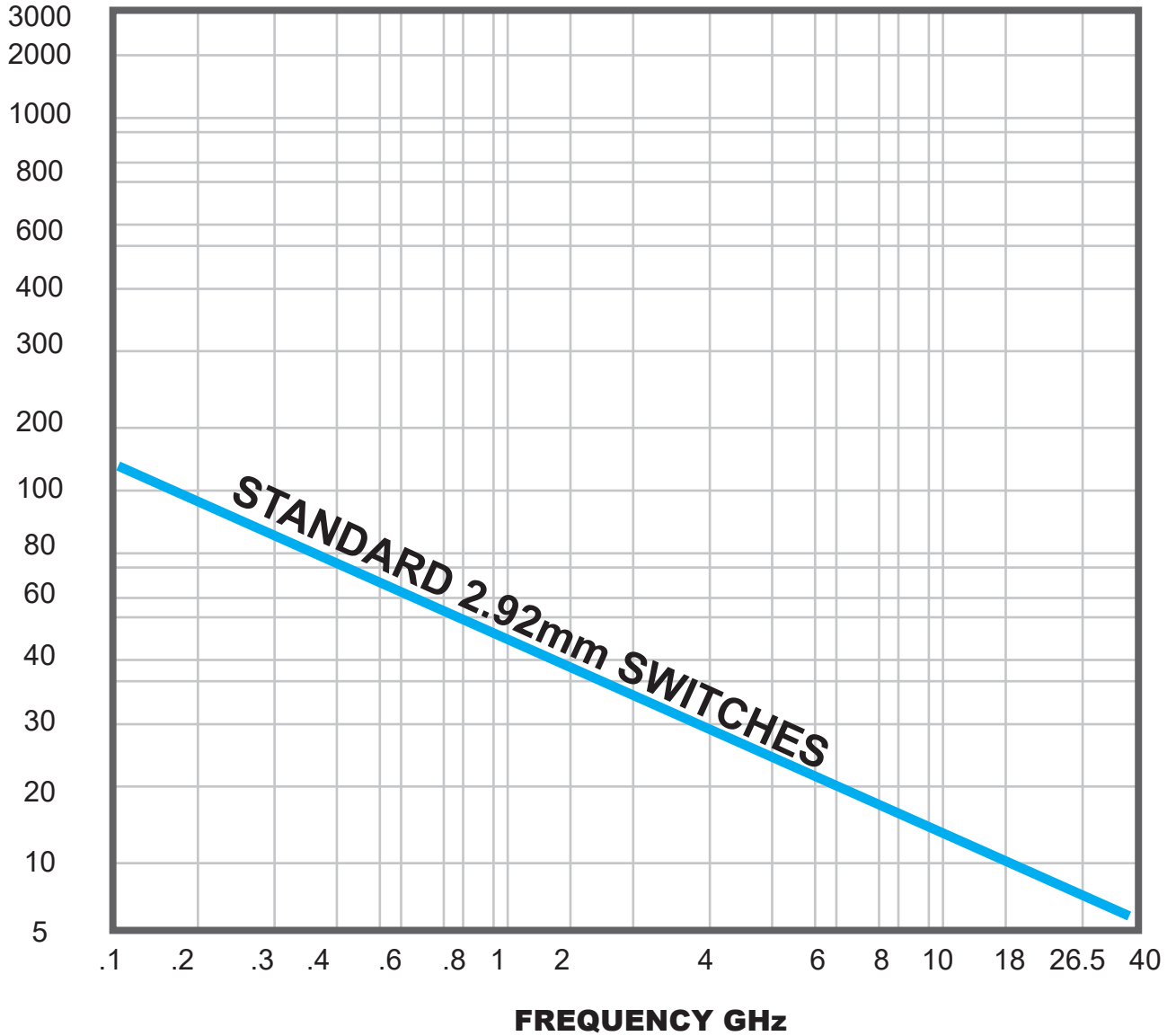

Estimates based on the following reference conditions:

- Ambient temperature of 40°C or less
- Sea level operation
- Load VSWR of 1.20:1 maximum
- No high-power (hot) switching

Please contact Teledyne Coax Switches for derating factors when applications do not meet the foregoing reference conditions.

GLOSSARY

Actuator

An actuator is the electromechanical mechanism that transfers the RF contacts from one position to another upon DC command.

Arc Suppression Diode

A diode is connected in parallel with the coil. This diode limits the “reverse EMF spike” generated when the coil de-energizes to 0.7 volts. The diode cathode is connected to the positive side of the coil and the anode is connected to the negative side.

Date Code

All switches are marked with either a unique serial number or a date code. Date codes are in accordance with MIL-STD-1285 Paragraph 5.2.5 and consist of four digits. The first two digits define the year and the last two digits define the week of the year (YYWW). Thus, 1032 identifies switches that passed through final inspection during the 32nd week of 2010.

Fail-safe

A fail-safe switch reverts to the default or fail-safe position when actuating voltage is removed. This is realized by a return spring within the drive mechanism. This type of switch requires the continuous application of operating voltage to select and hold any position. (Multi-position switches are normally open with no voltage applied).

Latching

A latching switch remains in the selected position whether or not voltage is maintained. This can be accomplished with either a magnetic or mechanical latching mechanism.

Indicator

Indicators tell the system which position the switch is in. Other names for indicators are telemetry contacts or tell back circuit. Indicators are usually a set of internally mounted DC contacts linked to the actuator. They can be wired to digital input lines, status lights, or interlocks. Unless otherwise specified, the maximum indicator contact rating is 30 Vdc, 50 mA, or 1.5 Watts into a resistive load.

Internal Termination

Unselected ports are internally terminated to a matched load. The load is 50Ω resistive device. The max RF power rating is 2 Watts CW. Without the internal termination option, the unselected ports are open circuits.

Isolation

Isolation is the measure of the power level at the output connector of an unconnected RF channel as referenced to the power at the input connector. It is specified in dB below the input power level.

Self-Cutoff

The self-cutoff option disables the actuator current on completion of actuation. Either a series contact (linked to the actuator) or an IC driver circuit provides the current cutoff. This option results in minimum power consumption by the RF switch. Cutthroat is another name used in the industry for this option. Pulse latching is a term used to describe a switch without this feature.

SPDT Switch

A single-pole-double-throw, has one input and two output ports.

Switching Time

Switching time is the total interval beginning with the arrival of the leading edge of the command pulse at the switch DC input and ending with the completion of the switch transfer, including contact bounce. It consists of three parts: (1) inductive delay in the coil, (2) transfer time of the physical movement of the contacts, and (3) the bounce time of the RF contacts.

TTL Switch Driver Option

As a special option, switch drivers can be provided for both fail-safe and latching switches, which are compatible with industry-standard low-power Schottky TTL circuits.

Performance Parameters vs Frequency

Generally speaking, the RF performance of coaxial switches is frequency dependent. With increasing frequency, VSWR and insertion loss increase while isolation decreases.

All data sheets specify these three parameters as “worst case” at the highest operating frequency. If the switch is to be used over a narrow frequency band, better performance can be achieved.

Actuator Current vs Temperature

The resistance of the actuator coil varies as a function of temperature. There is an inverse relationship between the operating temperature of the switch and the actuator drive current. For switches operating at 28 VDC, the approximate actuator drive current at temperature, T, can be calculated using the equation:

$$I_T = \frac{I_A}{[1 + .00385 (T-20)]}$$

Where:

I_T = Actuator current at temperature, T

I_A = Room temperature actuator current – see data sheet

T = Temperature of interest in °C

Magnetic Sensitivity

An electromechanical switch can be sensitive to ferrous materials and external magnetic fields. Neighboring ferrous materials should be permitted no closer than 0.5 inches and adjacent external magnetic fields should be limited to a flux density of less than 5 Gauss.