



PART NUMBER	DESCRIPTION
CCR-39U	DC-52 GHz, Single Pole Multi-Throw Latching Coaxial Switch
CR-39U	Elite, DC-52 GHz, Single Pole Multi-Throw Latching Coaxial Switch

CCR-39U is a broadband, SPnT, electromechanical coaxial switch designed to switch a microwave signal from a common input to any of its multiple outputs. These switches are designed for the frequency range from DC to 52GHz featuring excellent RF and mechanical performance with broadband operation, high isolation and low insertion loss. The characteristic impedance is 50Ω. Each position has an individual actuation mechanism which allows random position selection with minimum switching time. CCR-39U switches incorporate 2.4 mm high performance connectors and are compatible with most common mounting hole patterns which make them interchangeable with a wide variety of switches.



ENVIRONMENTAL AND PHYSICAL CHARACTERISTICS	
Storage Temperature	-55°C to 90°C
Operating Temperature	
CCR-39U	-25°C to 65°C
CR-39U	-55°C to 85°C
CR-39U w/ indicator contacts	-45°C to 85°C
Vibration <sup>1</sup> , 10 ~ 2000 Hz, 300 s MIL-STD-202 Method 204, Condition C	10 G peak
Shock, Half-Sine Pulse MIL-STD-202 Method 213, Condition D	500 G peak
Moisture Resistance <sup>2</sup>	95% RH Non-condensing
Mechanical Life	5,000,000 cycles (min)
Mechanical Life w/ Additional Features	1,000,000 cycles (min)
Connector Type	2.4 mm (U)
Weight	5.82 oz. approx (165 g)

ELECTRICAL CHARACTERISTICS	
RF Contacts	Break before make
Frequency Range	DC – 52 GHz
Characteristic Impedance	50Ω
Switching Time	20 ms max
Actuation Voltage (VDC) 20°C	12 15 24 28
Latching Current (mA)	Visit Voltage/Current Table (pg. 3)
Reset Current (mA)	Visit Voltage/Current Table (pg. 3)
TTL/Decoders Voltage/Current <sup>1</sup>	
Low Level (Logic 0)	0.0 ~ 0.7 V / 3.2 mA Max at 0.7 V
High Level (Logic 1)	2.4 ~ 5.5 V / 80 μA Max at 2.4 V
Indicator Contact Rating <sup>2</sup>	30 Vdc, 50 mA max
Magnetic Sensitivity	5 Gauss, 0.5 inch max

1. Non-operating
2. When moisture seal option is selected

1. For switches with TTL driver or decoder
2. For switches with indicator

RF CHARACTERISTICS							
Frequency	DC–6 GHz	6–12.4 GHz	12.4–18 GHz	18–26.5 GHz	26.5–40 GHz	40–50 GHz	50–52 GHz
Insertion Loss (max)	0.2 dB	0.4 dB	0.5 dB	0.7 dB	0.9 dB	1.3 dB	2.3 dB
Isolation (min)	70 dB	60 dB	60 dB	55 dB	50 dB	50 dB	50 dB
VSWR (max)	1.30:1	1.40:1	1.50:1	1.70:1	1.90:1	2.20:1	2.80:1

Please see charts on page 4.

**PART NUMBERING SYSTEM**

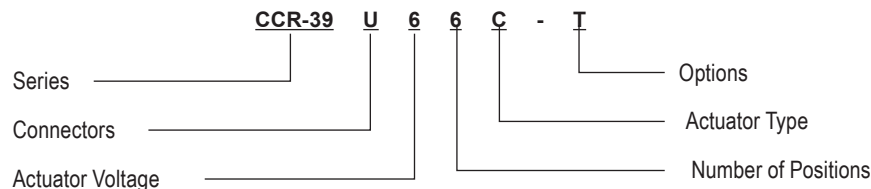

Connectors	Actuator Voltages	Number of Positions	Actuator Types	Available Options
2.4 mm (U) Female	6: 28 VDC 7: 15 VDC 8: 12 VDC 9: 24 VDC	4: SP4T 6: SP6T	0: Standard Contacts C: Indicator Contacts D: Self Cut-Off E: Indicator Contacts and Self Cut-Off	A: Auto Reset D: Transient Suppression and Polarity Protection Diodes T: TTL Driver with Diodes TD: TTL Driver with Decoder and Diodes R: Positive (+) Common or Reverse Polarity M: Moisture Resistant S: D-Sub Connector (Male)

Please feel free to contact us for more information regarding additional options and custom configurations.

**SCHEMATICS AND MECHANICAL OUTLINE**

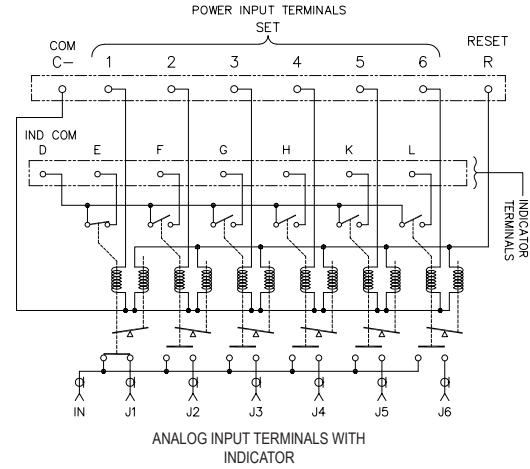
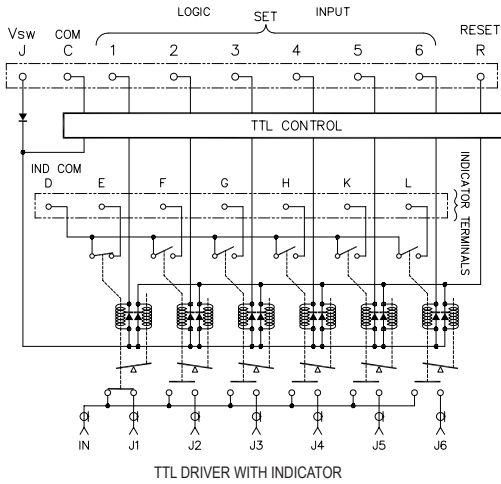

**ACTUATION CHARACTERISTICS:**

- REQUIRES TWO (2) SEQUENTIAL PULSES (RESET & SET)
- T1 & T2 = 30 mSEC MIN
- T3 = 10 mSEC MIN
- T4 & T5 = 20 mSEC MAX
- WITH AUTO RESET OPTION, RESET PULSE WILL BE APPLIED AUTOMATICALLY BEFORE EACH ACTUATION.

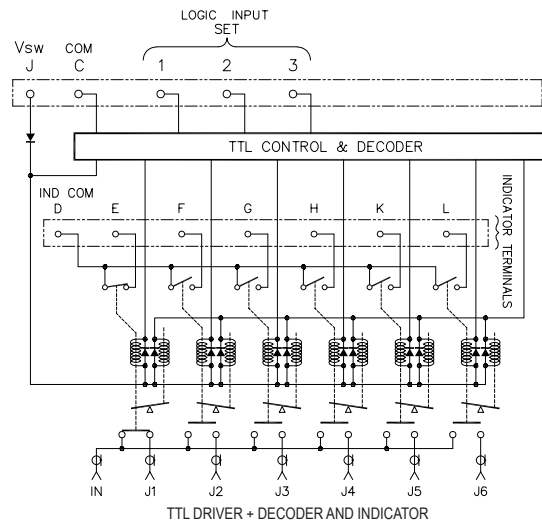
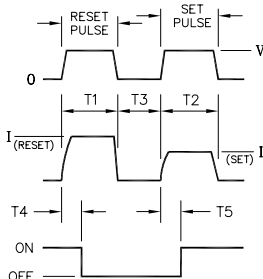

**D-Sub Model\***

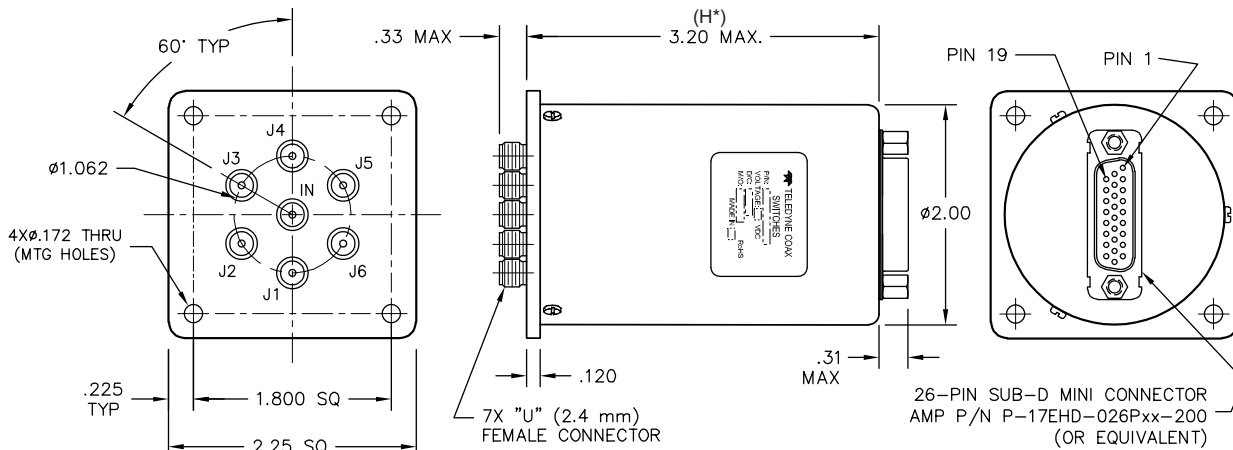

\*Height H will change based on options selected  
H = 2.52 max for standard model with no options  
H = 3.20 max with Indicators/ Self Cut-off / TTL  
H = 3.20 max with D-Sub Connector  
- Contact factory for additional model outlines

**ELECTRICAL PINOUT AND TRUTH TABLES**

ACTUATION VOLTAGES & CURRENTS				
Switch Configuration	Actuation Voltage (Vdc)	Set Current (mA)	Reset Current (mA)	Set Current (mA) W/ Auto Reset
SP6T	12	280	1680	N/A
	15	250	1500	N/A
	24	150	900	400
	28	110	660	N/A
SP4T	12	280	1680	N/A
	15	250	1500	N/A
	24	150	900	400
	28	110	440	660

15 & 26 PIN D-SUB PINOUT						
OPTIONS						
Pin No.	Basic	Indicators	TTL	Indicators & TTL	TTL + Decoder	Indicators & TTL + Decoder
1	J1 (1)	J1 (1)	J1 (1)	J1 (1)	LOGIC 1	LOGIC 1
2	J2 (2)	J2 (2)	J2 (2)	J2 (2)	LOGIC 2	LOGIC 2
3	J3 (3)	J3 (3)	J3 (3)	J3 (3)	LOGIC 3	LOGIC 3
4	J4 (4)	J4 (4)	J4 (4)	J4 (4)		
5	J5 (5)	J5 (5)	J5 (5)	J5 (5)		VSW (J)
6	J6 (6)	J6 (6)	J6 (6)	J6 (6)		
7	COM (C)	COM (C)	COM (C)	COM (C)	COM (C)	COM (C)
8	RESET (R)	RESET (R)	RESET (R)	RESET (R)		
9		IND COM (D)	VSW (J)	VSW (J)	VSW (J)	IND COM (D)
10		IND J1 (E)				IND J1 (E)
11		IND J2 (F)				IND J2 (F)
12		IND J3 (G)				IND J3 (G)
13		IND J4 (H)				IND J4 (H)
14		IND J5 (K)				IND J5 (K)
15		IND J6 (L)		IND COM (D)		IND J6 (L)
16				IND J1 (E)		
17				IND J2 (F)		
18				IND J3 (G)		
19				IND J4 (H)		
20				IND J5 (K)		
21				IND J6 (L)		
22						
23						
24						
25						
26						

**TRUTH TABLE  
TTL + DECODER OPTION**

LOGIC INPUT			RF PATH					INDICATOR POSITION							
1	2	3	J1	J2	J3	J4	J5	J6	RESET	E	F	G	H	K	L
0	0	0	ON	OFF	OFF	OFF	OFF	OFF	OFF	C	0	0	0	0	0
1	0	0	OFF	ON	OFF	OFF	OFF	OFF	OFF	0	C	0	0	0	0
0	1	0	OFF	OFF	ON	OFF	OFF	OFF	OFF	0	0	C	0	0	0
1	1	0	OFF	OFF	OFF	ON	OFF	OFF	OFF	0	0	0	C	0	0
0	0	1	OFF	OFF	OFF	OFF	ON	OFF	OFF	0	0	0	0	C	0
1	0	1	OFF	OFF	OFF	OFF	OFF	ON	OFF	0	0	0	0	0	C
0	1	1	RESET					0	0	0	0	0	0	0	0
1	1	1	COIL OFF					0	0	0	0	0	0	0	

**RF PERFORMANCE CURVES**

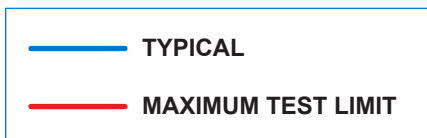
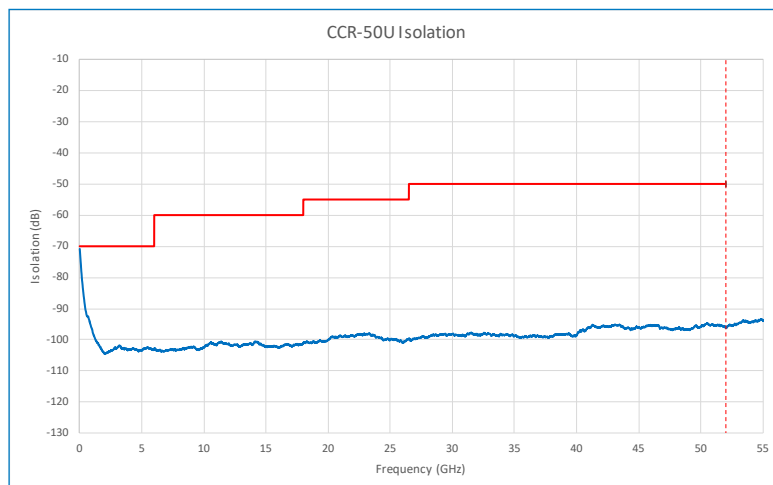
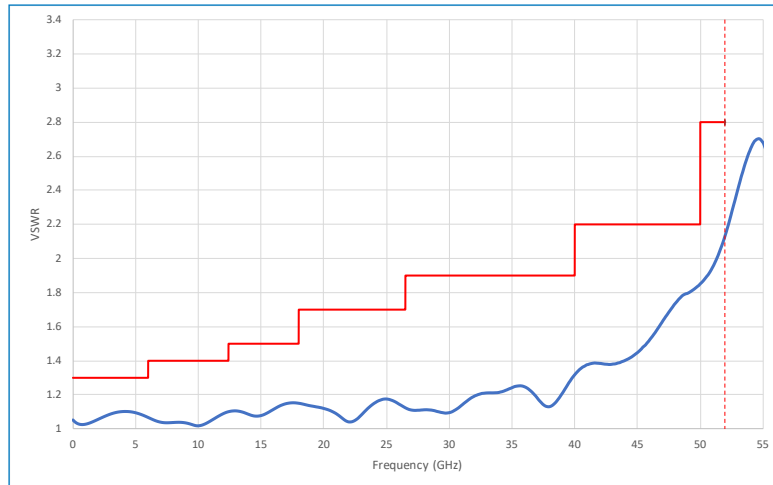
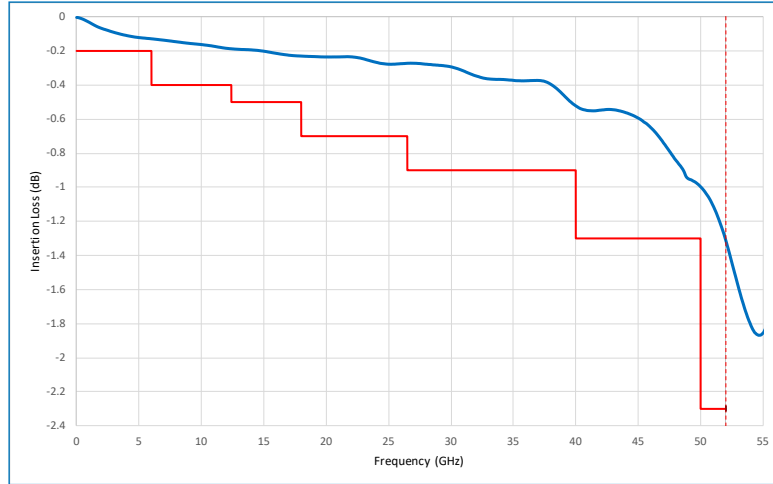

**POWER PERFORMANCE CURVE**

**Power Handling vs. Frequency**

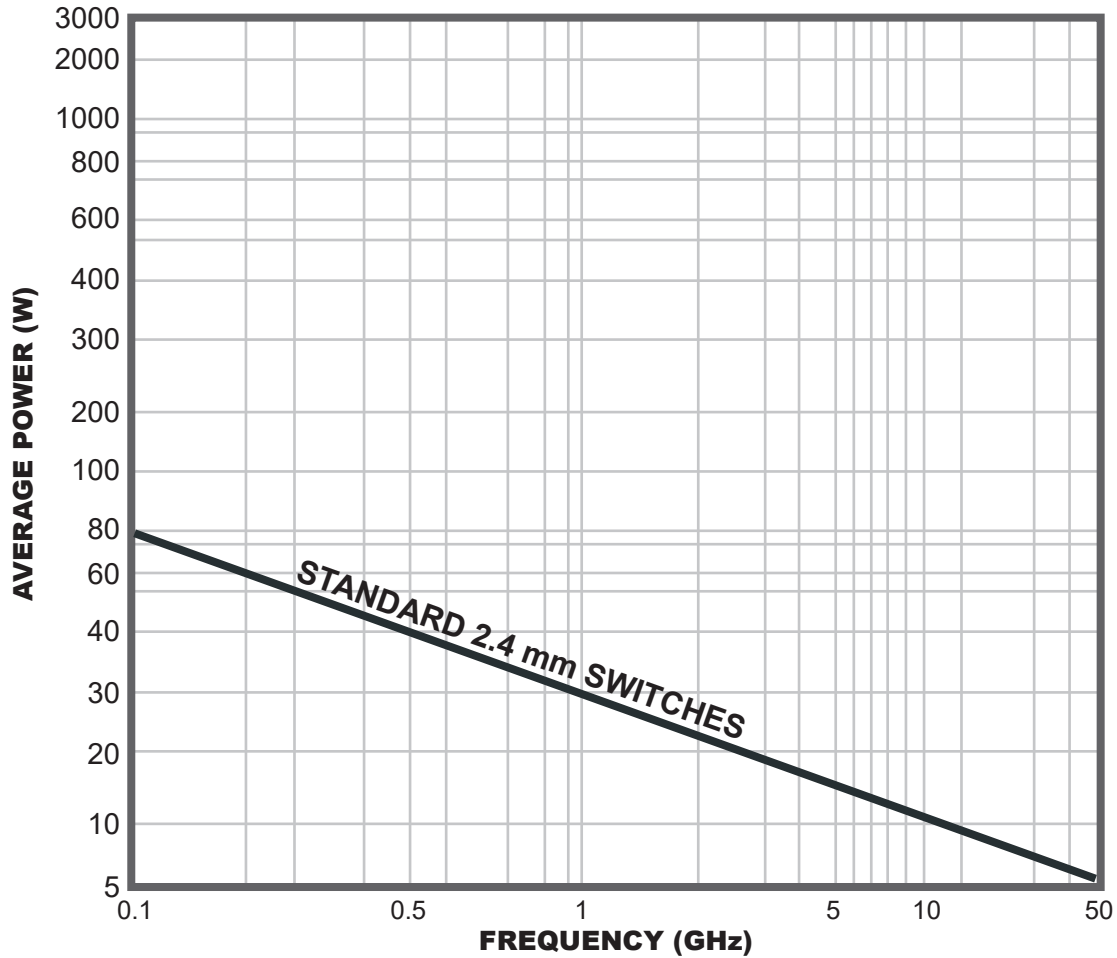

**Power Handling Derating vs. Load VSWR**

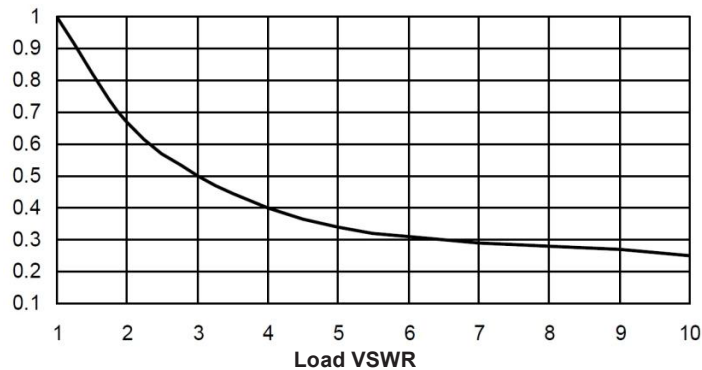

Estimates based on the following reference conditions:

- Ambient temperature of 40°C or less
- Sea level operation
- Load VSWR of 1.20:1 maximum
- No high-power (hot) switching

## GLOSSARY

### Actuator

An actuator is the electromechanical mechanism that transfers the RF contacts from one position to another upon DC command.

### Arc Suppression Diode

A diode is connected in parallel with the coil. This diode limits the “reverse EMF spike” generated when the coil de-energizes to 0.7 volts. The diode cathode is connected to the positive side of the coil and the anode is connected to the negative side.

### Date Code

All switches are marked with either a unique serial number or a date code. Date codes are in accordance with MIL-STD-1285 Paragraph 5.2.5 and consist of four digits. The first two digits define the year and the last two digits define the week of the year (YYWW). Thus, 1032 identifies switches that passed through final inspection during the 32nd week of 2010.

### Fail-safe

A fail-safe switch reverts to the default or fail-safe position when actuating voltage is removed. This is realized by a return spring within the drive mechanism. This type of switch requires the continuous application of operating voltage to select and hold any position. (Multi-position switches are normally open with no voltage applied).

### Latching

A latching switch remains in the selected position whether or not voltage is maintained. This can be accomplished with either a magnetic or mechanical latching mechanism.

### Indicator

Indicators tell the system which position the switch is in. Other names for indicators are telemetry contacts or tell back circuit. Indicators are usually a set of internally mounted DC contacts linked to the actuator. They can be wired to digital input lines, status lights, or interlocks. Unless otherwise specified, the maximum indicator contact rating is 30 Vdc, 50 mA, or 1.5 Watts into a resistive load.

### Internal Termination

Unselected ports are internally terminated to a matched load. The load is 50Ω resistive device. The max RF power rating is 2 Watts CW. Without the internal termination option, the unselected ports are open circuits.

### Isolation

Isolation is the measure of the power level at the output connector of an unconnected RF channel as referenced to the power at the input connector. It is specified in dB below the input power level.

### Multi-Throw Switch

A multi-throw switch is a switch with one input and three or more output ports.

### Self-Cutoff

The self-cutoff option disables the actuator current on completion of actuation. Either a series contact (linked to the actuator) or an IC driver circuit provides the current cutoff. This option results in minimum power consumption by the RF switch. Cutthroat is another name used in the industry for this option. Pulse latching is a term used to describe a switch without this feature.

### SPDT Switch

A single-pole-double-throw, has one input and two output ports.

### Switching Time

Switching time is the total interval beginning with the arrival of the leading edge of the command pulse at the switch DC input and ending with the completion of the switch transfer, including contact bounce. It consists of three parts: (1) inductive delay in the coil, (2) transfer time of the physical movement of the contacts, and (3) the bounce time of the RF contacts.

### TTL Switch Driver Option

As a special option, switch drivers can be provided for both fail-safe and latching switches, which are compatible with industry-standard low-power Schottky TTL circuits.

### Performance Parameters vs. Frequency

Generally speaking, the RF performance of coaxial switches is frequency dependent. With increasing frequency, VSWR and insertion loss increase while isolation decreases. All data sheets specify these three parameters as “worst case” at the highest operating frequency. If the switch is to be used over a narrow frequency band, better performance can be achieved.

### Actuator Current vs. Temperature

The resistance of the actuator coil varies as a function of temperature. There is an inverse relationship between the operating temperature of the switch and the actuator drive current. For switches operating at 28 VDC, the approximate actuator drive current at temperature, T, can be calculated using the equation:

$$I_T = \frac{I_A}{[1 + .00385 (T-20)]}$$

### Where:

$I_T$  = Actuator current at temperature, T

$I_A$  = Room temperature actuator current – see data sheet

T = Temperature of interest in °C

### Magnetic Sensitivity

An electromechanical switch can be sensitive to ferrous materials and external magnetic fields. Neighboring ferrous materials should be permitted no closer than 0.5 inches and adjacent external magnetic fields should be limited to a flux density of less than 5 Gauss.