

## SURFACE MOUNT HIGH FREQUENCY, ACTIVE RF SWITCH SPDT

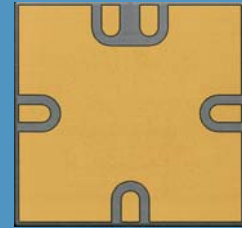

SERIES	SWITCH TYPE
InP1012	Solid State, InP-HEMT Active RF Switch DC - 60GHz

### DESCRIPTION

The InP1012-60 is a highly compact, reflective SPDT Active RF switch, manufactured using Teledyne's high-speed, low-loss InP HEMT process. The switch die is packaged in a low-loss, surface mount package, with a small form factor: 3mm (L) × 3mm (W) × 1mm (H). It supports a wide frequency range from DC to 60 GHz, and delivers low insertion loss, fast switching time, and good isolation—making this switch ideal for test and measurement, microwave communications, and radar applications. The InP1012-60 can also tolerate up to 100 krad of radiation, allowing it to be used in space applications.

#### The InP1012-60 features:

- Broad frequency bandwidth, greater than 60 GHz
- Small form factor, 3mm X 3mm X 1mm
- Low insertion loss
- Very High linearity
- Wide operating temperature
- Radiation tolerant up to 100 krad
- Very fast switching time of less than 100 ns
- RoHS Compliant

The following unique construction features and manufacturing techniques provide excellent robustness to environmental extremes and overall high reliability:

- Monolithic solid-state switch with no mechanical wear
- Flip-chip packaging provides shock & vibration resistance
- ENEPIG surface finish for solder bonding
- Low loss package with organic overmold
- Test board with K-connectors can be provided



### ENVIRONMENTAL AND PHYSICAL SPECIFICATIONS

<b>Temperature</b> (Ambient)	<b>Storage</b>	-65°C to +125°C
	<b>Operating</b>	-65°C to +125°C
<b>Enclosure</b>	Low-Loss Surface Mount Package	
<b>ESD Sensitivity (HBM)</b>	Class 1	
<b>MSL Sensitivity</b>	TBD	
<b>Radiation Tolerance</b>	100krads	

Teledyne Part Numbering System for InP1012

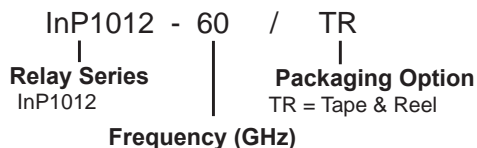

### INTERNAL CONSTRUCTION

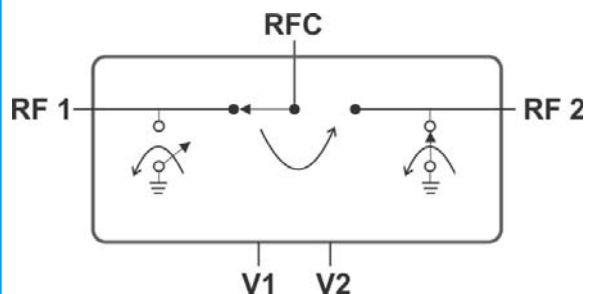

**InP1012-60**  
**TYPICAL RF CHARACTERISTICS (See RF Notes)**

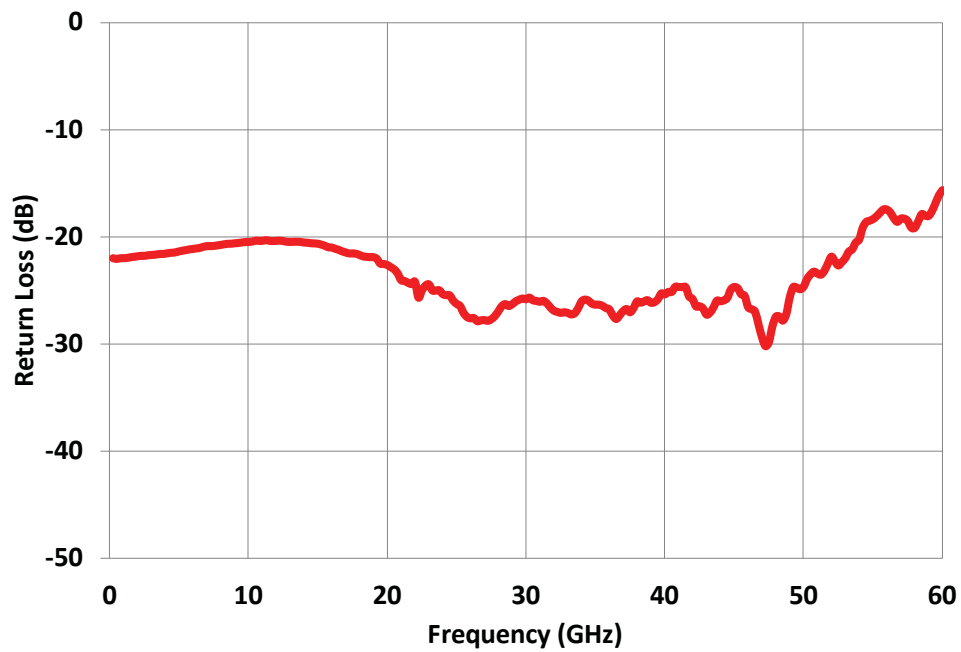
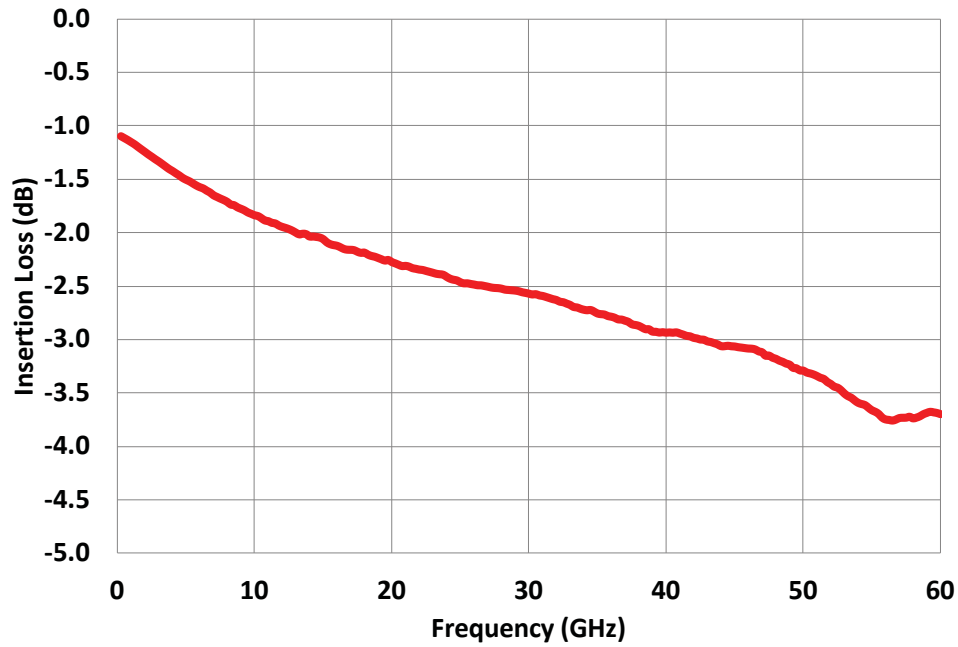

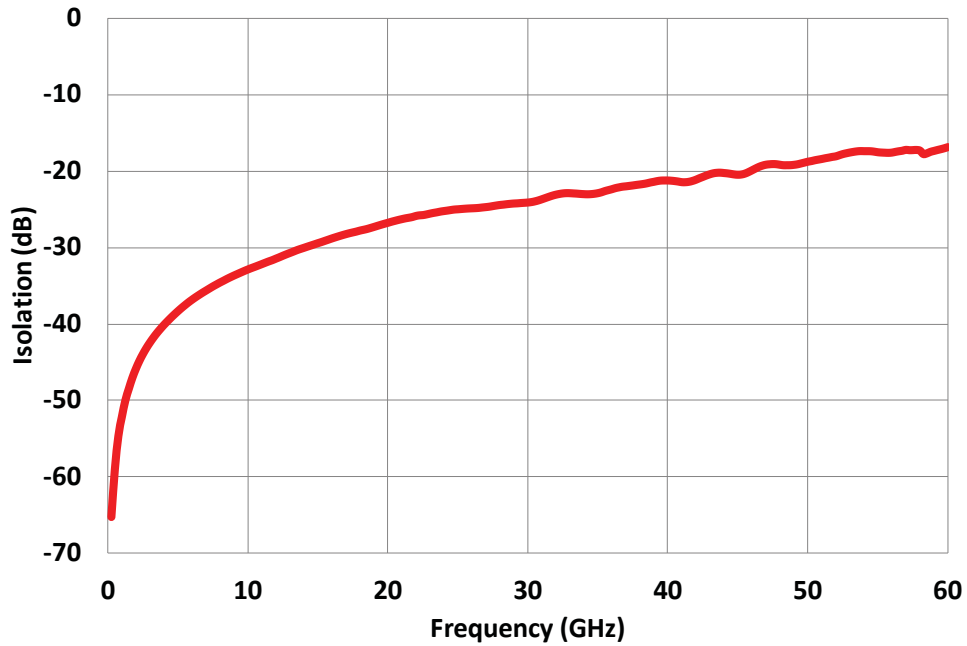

**TYPICAL POWER HANDLING CHARACTERISTICS**

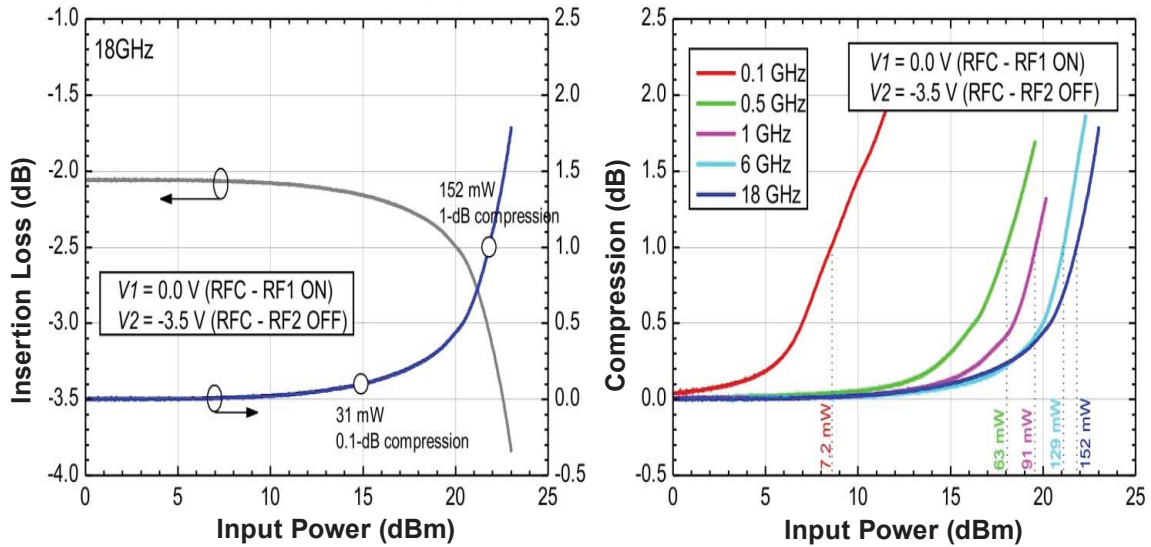

**RF NOTES**

- Test conditions:
  - See page 8 for test fixture information.
  - Room ambient temperature.
  - Terminals not tested were terminated with 50-ohm load.
  - Contact signal level: -10 dBm.
  - No. of test samples: 1.
- Data presented herein represents typical characteristics and is not intended for use as specification limits.

**TYPICAL ELECTRICAL SPECIFICATIONS (@25°C, V1 = ON, V2 = OFF OR V1 = OFF, V2 = ON, Z<sub>s</sub> = Z<sub>L</sub> = 50 Ω)**  
**OPERATING FREQUENCY: DC - 60 GHz**

Parameter/Condition	Path	Condition	Typical	Unit
Insertion Loss	RFC-RFX	DC (20mV - 200mV) *	2.0	dB
		10 kHz	0.9	dB
		100 MHz	1.2	dB
		6 GHz	1.6	dB
		14 GHz	2.0	dB
		20 GHz	2.3	dB
		30 GHz	2.6	dB
		40 GHz	2.9	dB
		50 GHz	3.3	dB
60 GHz	3.7	dB		
Isolation	RFC-RFX	10 kHz	67	dB
		100 MHz	60	dB
		6 GHz	37	dB
		14 GHz	30	dB
		20 GHz	27	dB
		30 GHz	24	dB
		40 GHz	21	dB
		50 GHz	19	dB
Isolation	RF1-RF2	100 MHz	69	dB
		100 MHz - 26.5 GHz	32	dB
		26.5-40 GHz	27	dB
		45- 60 GHz	17	dB
Return Loss (active port)	RFC-RFX	100 MHz	23	dB
		6 GHz	21	dB
		14 GHz	21	dB
		20 GHz	23	dB
		30 GHz	26	dB
		40 GHz	25	dB
		50 GHz	25	dB
60 GHz	16	dB		
Input 0.1dB compression point		100 MHz	3.1	dBm
		6 GHz	15.7	dBm
		18 GHz	14.9	dBm
Input 1dB compression point		100 MHz	8.6	dBm
		6 GHz	21.1	dBm
		18 GHz	21.8	dBm
Input 3 <sup>rd</sup> Order Intercept (IIP3)		10GHz	37.5	dBm

**GENERAL ELECTRICAL SPECIFICATIONS (@25°C)**

Contact Arrangement	1 Form C (SPDT)
Rated Duty	Continuous
Operating Power	1-2 mW
Switching Time	60-100 ns
DC Insertion Loss*	2.0 dB (20mV - 200mV Input Voltage)

\* Insertion loss increases with a higher DC offset, up to the 2.5Vdc Max.

**ABSOLUTE RATINGS**

Parameter/Condition	MIN	MAX	UNIT
Control Voltage (V1,V2)	-3.0	+0.3	V
RF Input Power P1.0 dB (RFC-RFX, 50Ω)		8.6 @ 100 MHz 21.1 @ 6 GHz 21.8 @ 18 GHz	dBm dBm dBm
RF Contact Maximum DC Offset		2.5	V
Maximum Junction Temperature*		+180 (est.)	°C
Storage Temperature Range*	-65	+180 (est.)	°C

\*InP die: 200°C for 30hours, BCB cure temperature: 250°C for 1hour, PbSn solder reflow temperature: 250°C for 1min, Pb37/Sn63 solder melting point: 183°C, MEG-TRON 6 substrate: 260°C, Sumitomo G770 epoxy overmold: 260°C

**RECOMMENDED OPERATING CONDITIONS**

Parameter	MIN	TYPICAL	MAX	UNIT
Control ON (V1,V2)	-0.3	0	+0.3	V
Control OFF (V1,V2)	-2.0	-2.5	-3.0	V
Control Current		200	700	μA

**Note:** Operation between -0.3V and -2.0V is not recommended.

**SWITCH STATES**

V1	V2	RF1	RF2	STATE
-2.5V	-2.5V	OFF	OFF	1
-2.5V	0V	OFF	ON	2
0V	-2.5V	ON	OFF	3
0V	0V	ON	ON	4

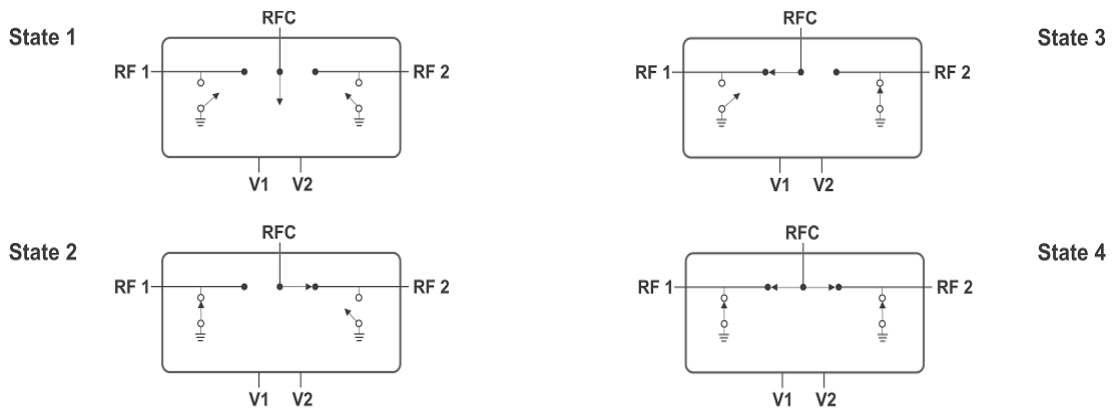



**InP1012-60**  
**TYPICAL SIGNAL INTEGRITY CHARACTERISTICS @ 40 Gbps+**

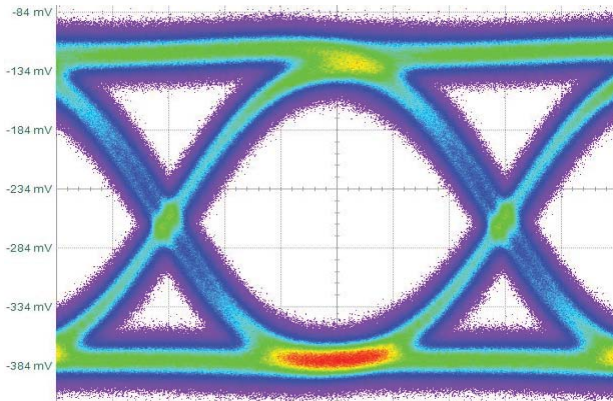

**Reference @ 40 Gbps**

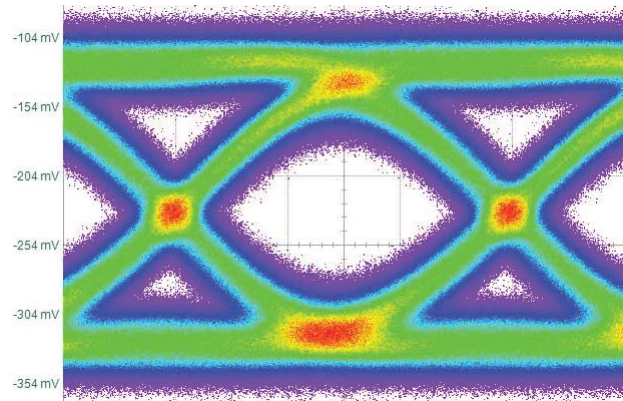

**InP1012-60 @ 40 Gbps**

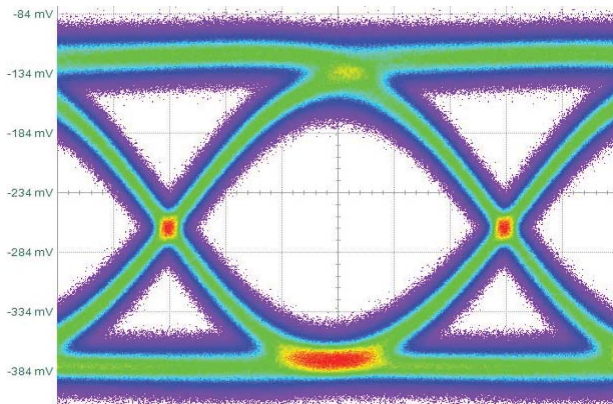

**Reference @ 48 Gbps**

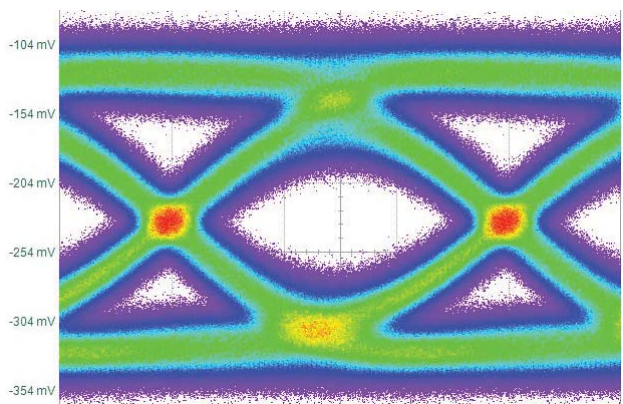

**InP1012-60 @ 48 Gbps**

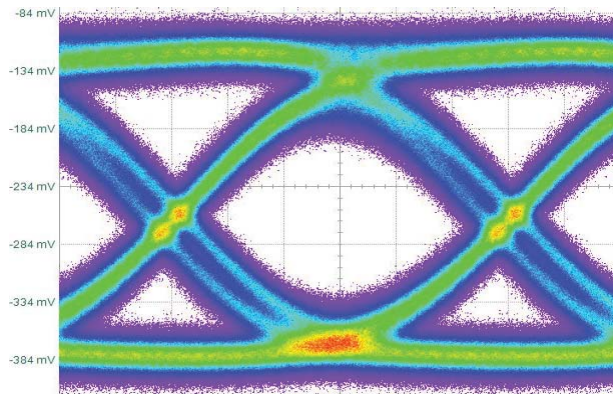

**Reference @ 56 Gbps**

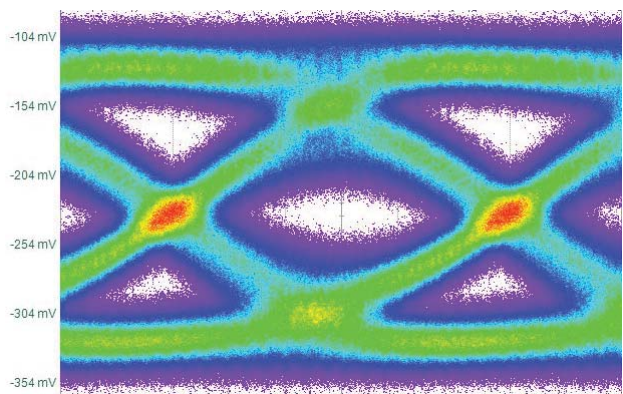

**InP1012-60 @ 56 Gbps**

**MEASUREMENTS NOTES**

DUT measurements were made using an oscilloscope.  
The relay was mounted on an evaluation board.

**Pattern Generator Settings**

- $2^{31} - 1$  PRBS signal
- 40Gbps data rate
- Data amplitude of 500mVpp

**OUTLINE DIMENSIONS**

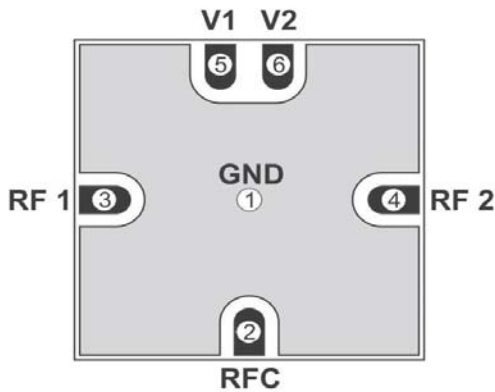
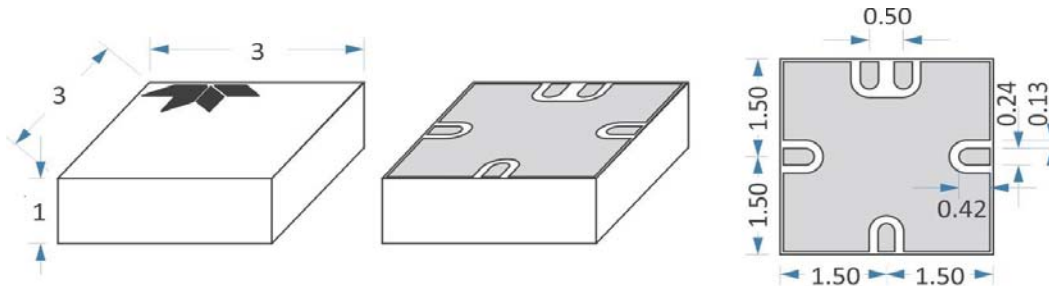

Pad No.	Pad Name	Description
1	GND	Ground
2	RFC	RF Common Port
3	RF1	RF Port 1
4	RF2	RF Port 2
5	V1	Control Input 1
6	V2	Control Input 2

**TAPE AND REEL PACKAGING OPTIONS**

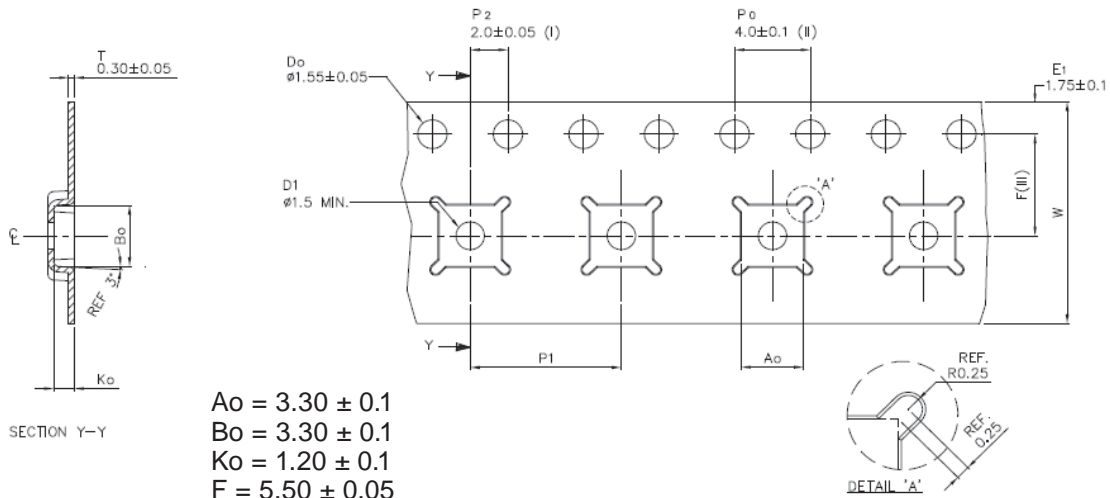

- Ao = 3.30 ± 0.1
- Bo = 3.30 ± 0.1
- Ko = 1.20 ± 0.1
- F = 5.50 ± 0.05
- P1 = 8.00 ± 0.1
- W = 12.00 ± 0.3

**Note:** Dimensions are in metric (mm).

**Notes:**

- 1) Cumulative Tolerance for 10 Sprocket Holes ± 0.2mm
- 2) Ao and Bo measured from a plane 0.3mm above bottom of pocket
- 3) Pocket position relative to sprocket hole and true position of pocket
- 4) Tape Engineered to comply with ANSI/EIA 481 B (July 2002)
- 5) Material does not contain heavy metals
- 6) Camber in compliance with ANSI/EIA 481 B (July 2002)

## Evaluation Board

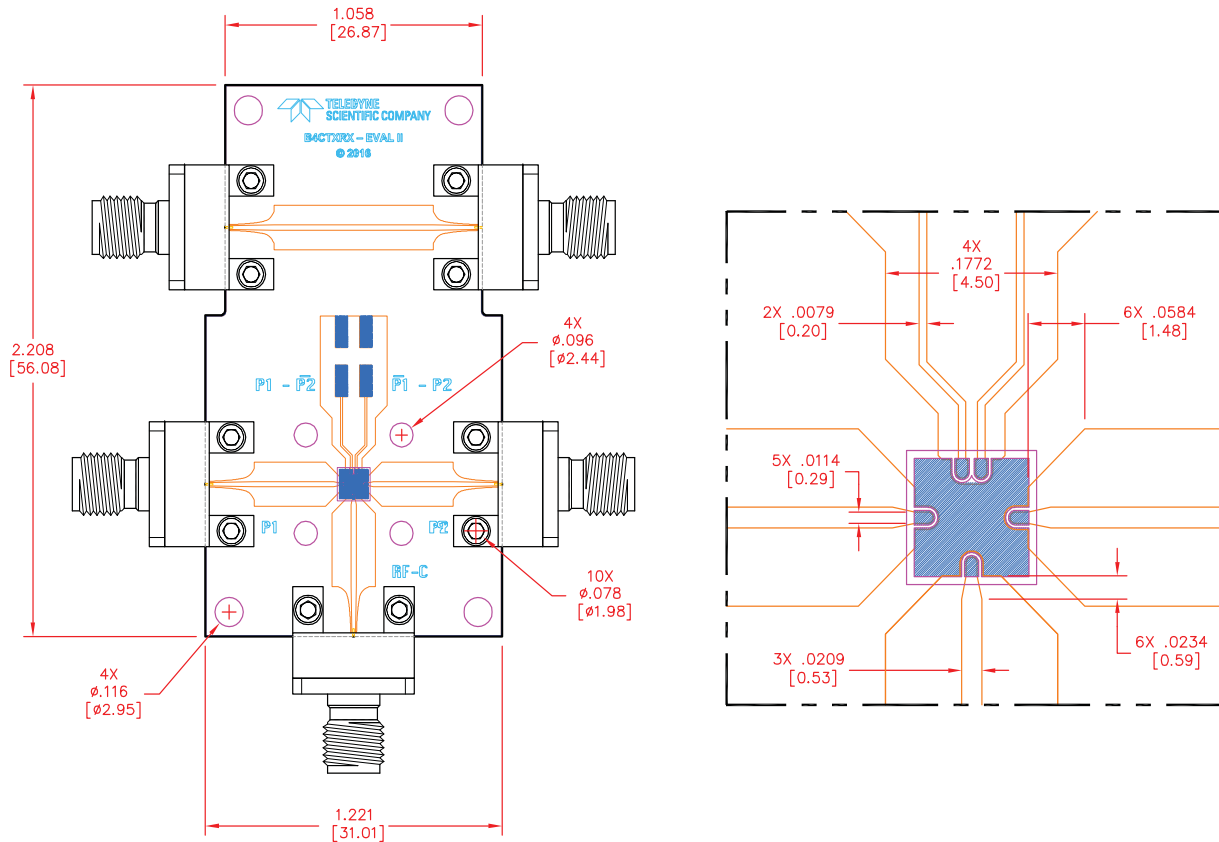

**Note:** RF and Signal Integrity measurements were made using the custom-built test board shown above .  
Fixture: .020" RO4350B, ENIG plated, with 2.4mm connectors (Trademark of Rogers Corporation.)  
RF ground pad is soldered to PCB RF ground plane.

To order the Evaluation Board, please use the following part number:

InP1012 - 60 / K  
 |                      |  
 Relay Series      Evaluation Board  
 InP1012  
 |  
 Frequency (GHz)



### Handling Guidelines for Active RF Switches (InP Series)

1. Do not drop, throw, or in any way mishandle individual switches or cartons containing switches.
2. Store switches in a humidity-controlled, shock- and vibration-free environment. Storage temperature range limits are  $-65^{\circ}\text{C}$  to  $+125^{\circ}\text{C}$ , however, when possible, switches should be stored in an ambient environment.
3. Do not expose switches to humid condition such that condensation may be formed due to sudden drop in temperature. Switches shall be stored in condensation free condition.
4. Do not stack heavy objects directly onto switches.
5. Active RF switches shall be treated as Electrostatic Discharge (ESD) sensitive and shall be handled accordingly. Always work in ESD protected station and wear wrist strap before handling the device.
6. When removing switches from packs, do so with extreme care. Do not allow the switches to fall onto any hard surface during unpacking. Do not “pour” the switches from the packing. Do not allow switches to fall onto the floor.
7. When transferring switches to a production area after unpacking, do so only in a suitable container, transport the devices in anti-static container, taking care not to drop the switches into the container, or to drop, throw or mishandle the container in any way.
8. For either metal-cover switches that are hermetically sealed or plastic switches that are not hermetically sealed, any damage to the casing, leads, or connector may compromise the relay’s performance and reliability.
9. Never subject switches to ultrasonic cleaning environment.
10. Do not submerge plastic switches, which are not hermetically sealed, in cleaning solution or spray aqueous cleaning solution directly onto switches.
11. For plastic switches, which are not hermetically sealed, switches should be baked before use. After bake, switches must be mounted within 8 hours. Switches must be baked again if this 8 hour time period is exceeded. The recommended bake profile is  $125^{\circ}\text{C}$  for 1 hour.
12. After the reflow/mounting process, switches should be baked again after cleaning, prior to a second reflow, or prior to conformal coating.
13. Unless otherwise specified, do not subject switches and relay terminals to reflow solder temperatures above  $245^{\circ}\text{C}$ , 6 seconds maximum. If hand soldering is used, the solder iron tip shall be properly grounded. Observe IPC J-HDBK- 001, paragraph 6.1.0.1 guidelines for heat sensitive components when hand soldering switches.
14. If reshipping product do so in original packaging from factory.
15. Switches should not be exposed to any process or environment that exceeds any limits within this guideline or any published specification that applies to the relay.