

**DETAIL SPECIFICATION FOR
HIREL 412V RELAYS**

**RELAYS, HIGH RELIABILITY,
HIGH VIBRATION,
ELECTROMECHANICAL,
NON-LATCHING, DPDT,
LOW LEVEL TO 1.0 AMPERE,
WITH OPTIONAL DIODE(S) FOR
COIL TRANSIENT SUPPRESSION AND
POLARITY REVERSAL PROTECTION**

TR-HIREL-1/412V

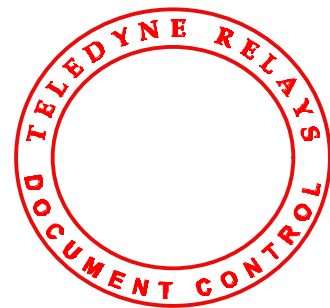

ISSUE 3

31 Oct. 2013

Issue or Amendment No.	Date of Issue	Approved by			
		Engineering	Operations	Product Assurance	Marketing
Issue 1	27 Feb 2001	AC DC	HW	SRL	DY
Issue 2	18 Jan 2006	JW AH	RT for HW	MT	DY
Issue 3	31 Oct 2013	4W		N.K	

TABLE OF CONTENTS.

1.	SCOPE	5
2.	RELAY CHARACTERISTICS	6
2.1.	GENERAL DATA.	6
2.1.1.	<i>Contact arrangement.</i>	<i>6</i>
2.1.2.	<i>Temperature range.</i>	<i>6</i>
2.1.3.	<i>Dimensions and configuration.</i>	<i>6</i>
2.1.4.	<i>Weight.</i>	<i>6</i>
2.1.5.	<i>Seal.</i>	<i>6</i>
2.1.6.	<i>Finish of the terminals.</i>	<i>6</i>
2.2.	PART NUMBER (ORDERING INFORMATION).	7
2.3.	CONTACT DATA.	8
2.3.1.	<i>Contact load and life ratings.</i>	<i>8</i>
2.3.2.	<i>Static contact resistance or voltage drop.</i>	<i>8</i>
2.3.3.	<i>Contact bounce time (when specified, see TR-HIREL-1/Supplement 1).</i>	<i>8</i>
2.3.4.	<i>Contact stabilization time (when specified, see TR-HIREL-1/Supplement 1).</i>	<i>8</i>
2.4.	ELECTRICAL DATA.	8
2.4.1.	<i>Insulation resistance.</i>	<i>8</i>
2.4.2.	<i>Dielectric withstanding voltage.</i>	<i>8</i>
2.4.3.	<i>Coil data and operating characteristics.</i>	<i>8</i>
2.4.4.	<i>Timing (over the temperature range).</i>	<i>8</i>
2.4.5.	<i>Diode characteristics.</i>	<i>8</i>
2.5.	MOUNTING VARIANTS.	8
2.6.	TERMINATION VARIANTS.	8
2.7.	TESTING SELECTION ID DESIGNATOR.	8
2.7.1.	<i>Manufacturing Variants.</i>	<i>8</i>
2.7.2.	<i>Screening Variants.</i>	<i>8</i>
2.8.	ENVIRONMENTAL DATA.	8
2.8.1.	<i>Shock.</i>	<i>8</i>
2.8.2.	<i>Vibration (sinusoidal).</i>	<i>8</i>
2.8.3.	<i>Vibration (resonant beam).</i>	<i>8</i>
3.	MARKING.....	8
4.	QUALITY ASSURANCE.....	8
4.1.	FINAL PRODUCTION TESTS.	8
4.2.	SCREENING AND ELECTRICAL MEASUREMENTS.	8
4.3.	LOT ACCEPTANCE TESTS (WHEN SPECIFIED, SEE TR-HIREL-1/SUPPLEMENT 1).	8
5.	GENERAL NOTES.....	8

TABLE OF TABLES.

TABLE 1. CONTACT LOAD AND LIFE RATINGS.	8
TABLE 2. STATIC CONTACT RESISTANCE OR VOLTAGE DROP.	8
TABLE 3. POINTS OF APPLICATION AND MEASUREMENT FOR INSULATION RESISTANCE AND DIELECTRIC WITHSTANDING VOLTAGE TESTS.	8
TABLE 4. COIL DATA AND OPERATING CHARACTERISTICS OF BASIC RELAYS <u>4</u> /.....	8
TABLE 5. COIL DATA AND OPERATING CHARACTERISTICS OF RELAYS WITH DIODE FOR COIL TRANSIENT SUPPRESSION.....	8
TABLE 6. COIL DATA AND OPERATING CHARACTERISTICS OF RELAYS WITH DIODE(S) FOR COIL TRANSIENT SUPPRESSION AND POLARITY REVERSAL PROTECTION.	8
TABLE 7. MOUNTING VARIANTS.....	8
TABLE 8. TERMINATION VARIANTS.....	8
TABLE 9. MANUFACTURING VARIANTS.	8
TABLE 10. SCREENING VARIANTS.	8
TABLE 11. ENVIRONMENTAL TESTS.	8
TABLE 12. FINAL PRODUCTION TESTS. <u>1</u> /.....	8
TABLE 13. SCREENING AND ELECTRICAL MEASUREMENTS. <u>1</u> /.....	8
TABLE 14. LOT ACCEPTANCE TEST 3. <u>1</u> /.....	8
TABLE 15. LOT ACCEPTANCE TEST 2. <u>1</u> /.....	8
TABLE 16. LOT ACCEPTANCE TEST 1. <u>1</u> /.....	8

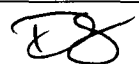
TABLE OF FIGURES.

FIGURE 1. OUTLINE DIMENSIONS.	5
FIGURE 2. TERMINAL LOCATIONS AND CIRCUIT DIAGRAM (BOTTOM VIEW).....	5
FIGURE 3. GROUND PIN POSITIONS.	8

TABLE OF APPENDICES.

APPENDIX A. MOUNTING AND TERMINATION VARIANTS.....	8
APPENDIX B. DOCUMENT CHANGE HISTORY.....	8

DETAIL SPECIFICATION FOR 412V RELAYS

RELAYS, HIGH RELIABILITY, HIGH VIBRATION, ELECTROMECHANICAL, NON-LATCHING, DPDT, LOW LEVEL TO 1.0 AMPERE, WITH OPTIONAL DIODE(S) FOR COIL TRANSIENT SUPPRESSION AND POLARITY REVERSAL PROTECTION

1. SCOPE

The performance and testing specifications for the above-referenced product are set forth in this detail specification. References to TR-HIREL-1 are to the most recent version thereof; in the event of conflict between this detail specification and TR-HIREL-1, the specifications set forth in this detail specification shall prevail.

Figure 1. Outline dimensions.

Figure 2. Terminal locations and circuit diagram (bottom view).

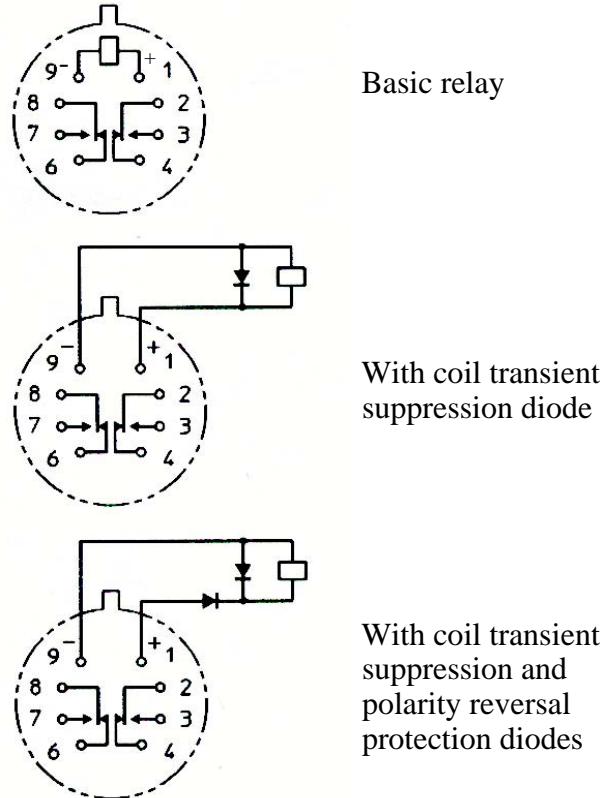
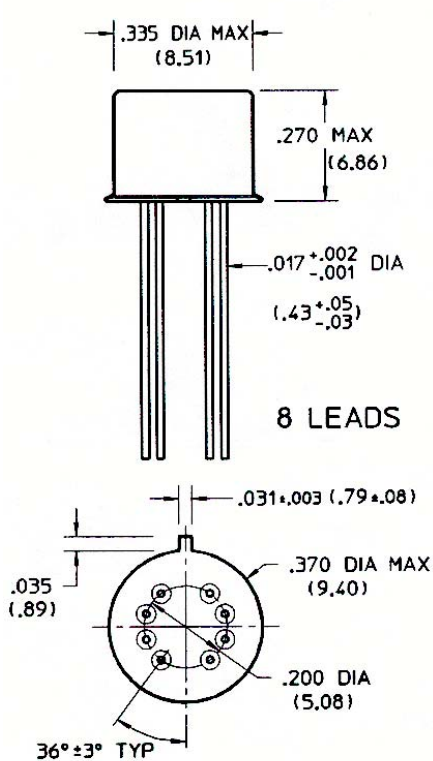

Basic relay

With coil transient suppression diode

With coil transient suppression and polarity reversal protection diodes

Notes to Figures 1 and 2:

1. The standard configuration is shown in Figure 1. See Appendix A herein for mounting and termination variants.
2. Dimensions are in inches. Metric equivalents in mm are given in parentheses.
3. Unless otherwise specified, the tolerance on dimensions is ± 0.010 in. (± 0.254 mm).
4. Circuit diagrams shown in Figure 2 are terminal views (as seen from the bottom of the relays).
5. Terminal numbers are not marked on the relays.

2. RELAY CHARACTERISTICS**2.1. General Data.****2.1.1. Contact arrangement.**

DPDT (2 Form C).

2.1.2. Temperature range.

−65 °C to +125 °C.

2.1.3. Dimensions and configuration.

See Figure 1 and Appendix A herein.

2.1.4. Weight.

2.55 g (0.09 oz) maximum.

- For relays supplied with M or M3 spreader pad (see Appendix A herein and TR-HIREL-1/Supplement 1), 2.80 g (0.10 oz) maximum;
- For relays supplied with M2 spreader pad (see Appendix A herein and TR-HIREL-1/Supplement 1), 3.26 g (0.115 oz) maximum.

2.1.5. Seal.

Hermetic. Leak rate 1×10^{-8} atm-cm³/s of air maximum.

2.1.6. Finish of the terminals.

Gold plated or solder coated (see Appendix A herein and TR-HIREL-1/Supplement 1).

2.2. Part Number (ordering information).

See TR-HIREL-1/Supplement 1 for checklist to be used for procurement.

a) For basic relay with no diode:

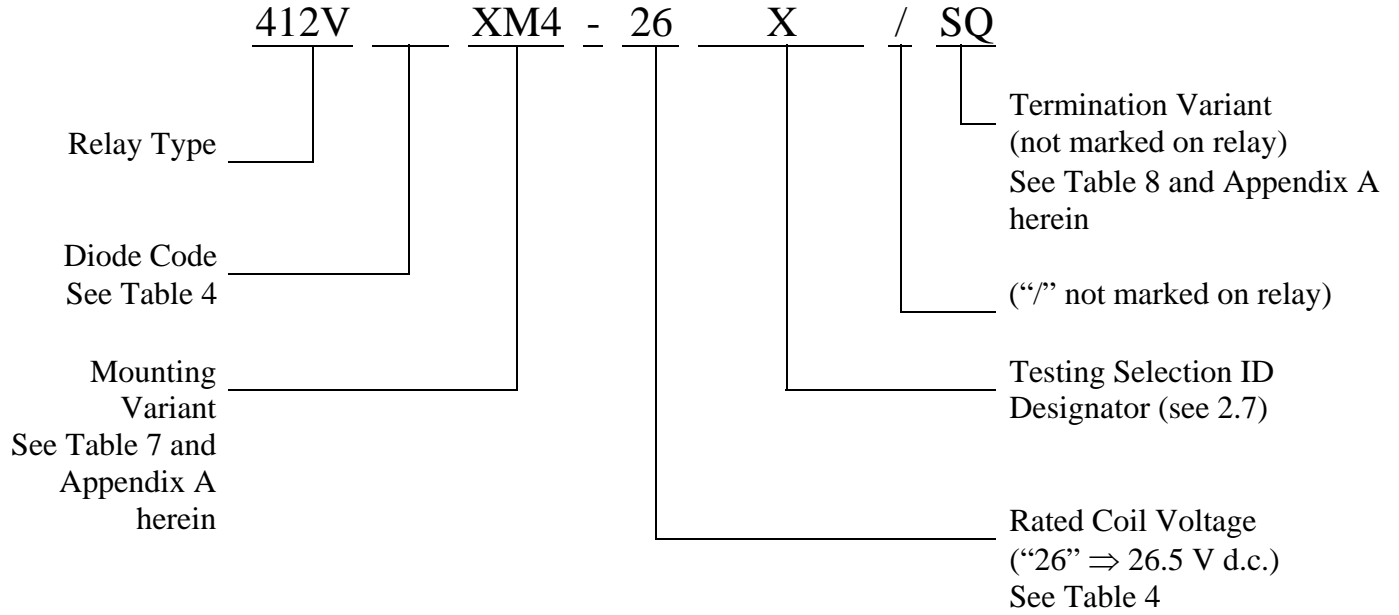

b) For relay with diode for coil transient suppression:

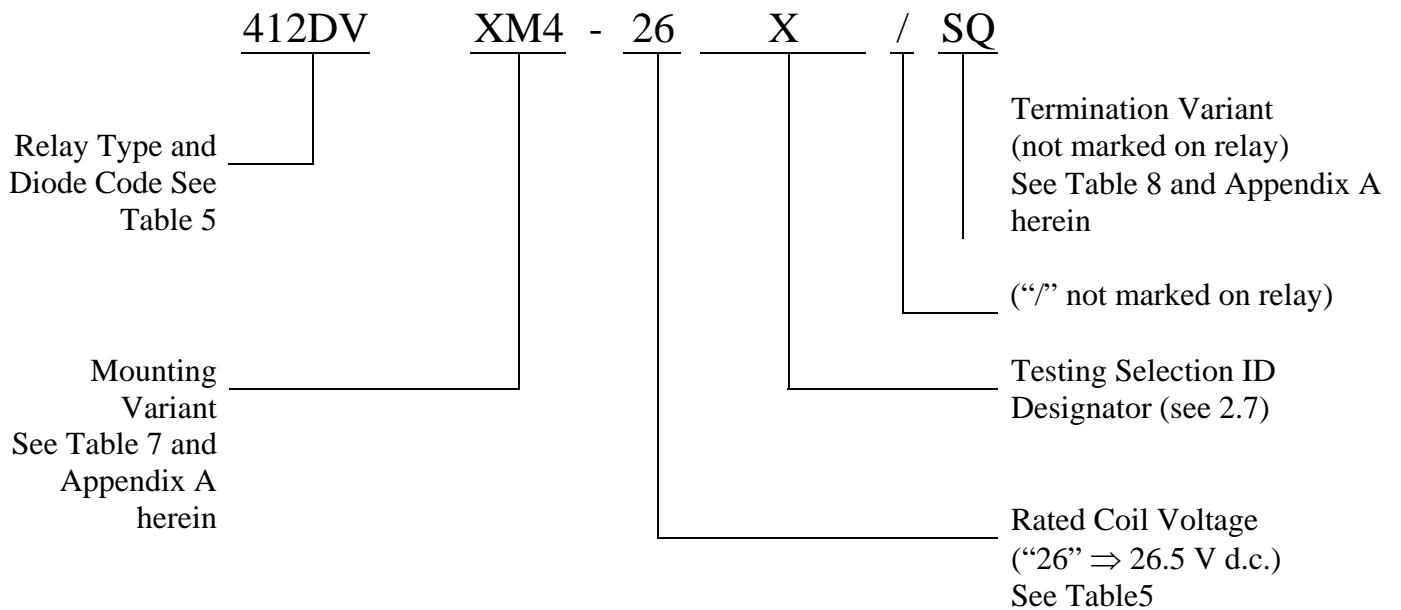

c) For relay with diode(s) for coil transient suppression and polarity reversal protection:

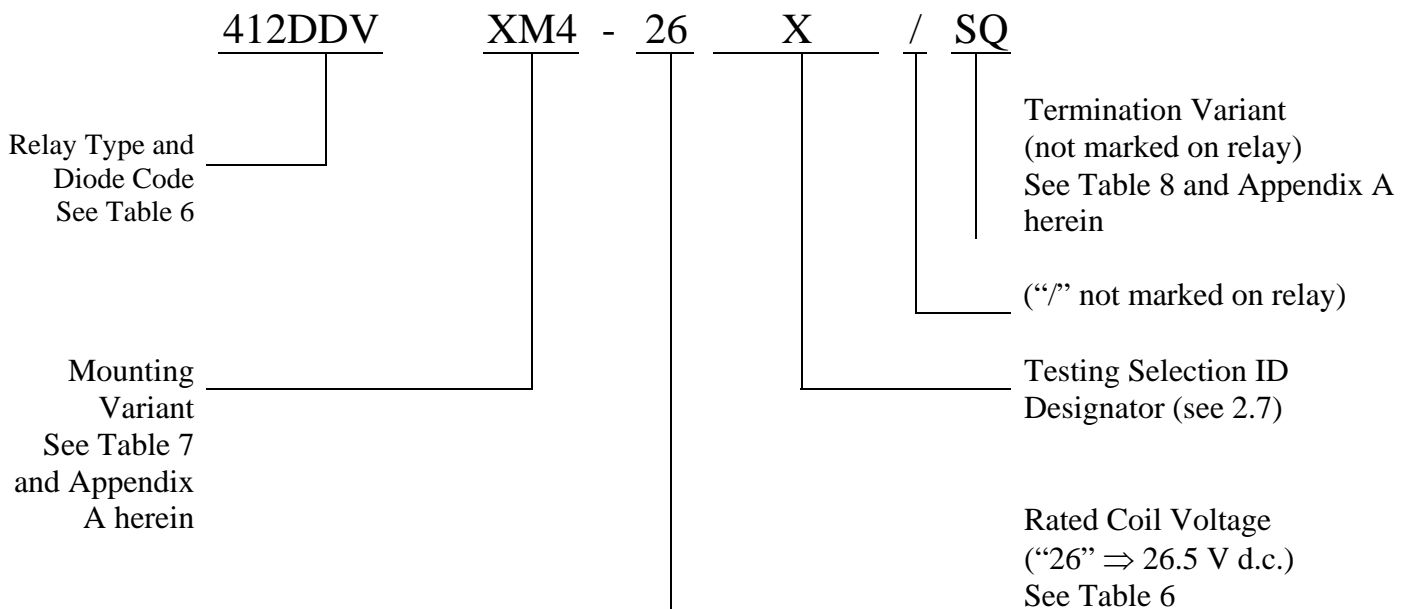

2.3. Contact Data.
2.3.1. Contact load and life ratings.

See Table 1.

2.3.2. Static contact resistance or voltage drop.

 See Table 2. Contact resistance measurements shall be made at approximately $\frac{1}{8}$ in. from the emergence of the lead from the seating plane of the relay.

2.3.3. Contact bounce time (when specified, see TR-HIREL-1/Supplement 1).

1.5 ms maximum.

2.3.4. Contact stabilization time (when specified, see TR-HIREL-1/Supplement 1).

2.5 ms maximum.

Table 1. Contact Load and Life Ratings.

Load level	Contact load ^{1/}	Contact life
Low level/Mechanical	10 – 50 μ A at 10 – 50 mV d.c. or peak a.c.	100,000 cycles rated life
		1,000,000 cycles unmonitored (Mechanical life)
Intermediate current	100 mA at 28 V d.c.	50,000 cycles
High level, resistive	1.0 A at 28 V d.c.	100,000 cycles
High level, inductive	200 mA at 28 V d.c., with 0.32 H inductance	100,000 cycles
High level, lamp	100 mA at 28 V d.c.	100,000 cycles
Overload, resistive	2.0 A at 28 V d.c.	100 cycles

Notes to Table 1:
^{1/} Relay case is grounded, unless otherwise specified.

Table 2. Static Contact Resistance or Voltage Drop.

Measurement condition		Maximum static contact resistance or voltage drop			
		without attached spacer/spreader pad	with M4 spacer pad attached	with M or M3 spreader pad attached	with M2 spreader pad attached
Initial		0.100 Ω	0.110 Ω	0.125 Ω	0.150 Ω
Low level life	during test	33 Ω (1.65 mV d.c. monitoring level)			
	after 100,000 or 1,000,000 cycle life	0.150 Ω	0.160 Ω	0.175 Ω	0.200 Ω
Intermediate Current	during test	1 Ω (100 mV d.c. monitoring level)			
	after 50,000 cycle test	0.200 Ω	0.210 Ω	0.225 Ω	0.250 Ω
High level life	during life	voltage drop no more than 5 % of open circuit voltage (1.4 V d.c. monitoring level)			
	after 100,000 cycle life	0.200 Ω	0.210 Ω	0.225 Ω	0.250 Ω
Overload	during test	not monitored			
	after 100 cycle life	0.200 Ω	0.210 Ω	0.225 Ω	0.250 Ω

2.4. Electrical Data.
2.4.1. Insulation resistance.

Points of measurement are as specified in Table 3. Coil leads of relays supplied with internal diode(s) should be connected together to avoid damage to the diode(s).

10,000 M Ω minimum at 500 V d.c., except as follows:

1,000 M Ω minimum at 500 V d.c. between coil and case at +125 °C

1,000 M Ω minimum at 500 V d.c. after 100 cycle overload,

100,000 cycle high level life, or 50,000 cycle intermediate current tests

2.4.2. Dielectric withstanding voltage.

Points of application are as specified in Table 3. Coil leads of relays supplied with internal diode(s) should be connected together to avoid damage to the diode(s).

2.4.2.1. At atmospheric pressure.

500 V r.m.s. \pm 5 % at 50 or 60 Hz (as applicable), except as follows:

375 V r.m.s. at 50 or 60 Hz (as applicable) after 100 cycle overload, 100,000 cycle high level life, or 50,000 cycle intermediate current tests

Table 3. Points of Application and Measurement for Insulation Resistance and Dielectric Withstanding Voltage Tests.

Points of Application / Measurement	De-energized position	Energized position
Between case, frame, or enclosure, and all contacts	✓	✓
Between case, frame, or enclosure and coil	✓	
Between all contacts and coil	✓	
Between open contacts	✓	✓
Between contact poles	✓	✓

- 2.4.3. **Coil data and operating characteristics.**
See Tables 4, 5 and 6.
- 2.4.4. **Timing (over the temperature range).**
 - 2.4.4.1. **Operate time.**
3.0 ms maximum with rated coil voltage.
 - 2.4.4.2. **Release time.**
2.0 ms maximum from rated coil voltage.
 - 2.4.4.3. **Release time with diode(s).**
4.0 ms maximum from rated coil voltage.
- 2.4.5. **Diode characteristics.**
 - 2.4.5.1. **Coil transient suppression.**
1.0 V d.c. maximum negative transient.
 - 2.4.5.2. **Block integrity maximum leakage current.**
1 μ A at 50 V d.c.
 - 2.4.5.3. **Breakdown voltage.**
100 V d.c. minimum at 10 μ A.

Table 4. Coil Data and Operating Characteristics of Basic Relays 4/.

Coil voltage (V d.c.) <u>2</u> /		Room ambient temperature (+25 °C)				Over temperature range		
Rated	Max	Coil resistance (Ω) ± 10 %	Pickup voltage (V d.c.) max <u>3</u> /	Hold voltage (V d.c.) max <u>3</u> /	Dropout voltage (V d.c.) min <u>3</u> /	Pickup voltage (V d.c.) max <u>3</u> /	Hold voltage (V d.c.) max <u>3</u> /	Dropout voltage (V d.c.) min <u>3</u> /
5.0	5.8	50	3.38	1.25	0.27	4.6	2.3	0.14
6.0	8.0	70	4.05	1.5	0.32	5.5	3.2	0.18
9.0	12.0	155	6.1	2.3	0.48	8.2	4.9	0.35
12.0	16.0	235	8.1	3.0	0.65	11.0	6.5	0.41
18.0	24.0	610	12.2	4.5	0.97	16.5	10.0	0.59
26.5	32.0	1130	16.3	6.0	1.3	22.0	13.0	0.89

Notes to Table 4:

1. Each relay possesses high level and low level capabilities. However, relays previously tested or used above 10 mA resistive at 6 V d.c. maximum or peak a.c. open circuit are not recommended for subsequent use in low level applications.
- 2/ The use of any coil voltage other than the rated coil voltage will affect the electrical and dynamic characteristics of the relay.
- 3/ Relay contacts shall transfer to the energized position at a voltage no greater than the maximum pickup voltage, hold in the energized position when the coil voltage is reduced from rated coil voltage to the maximum hold voltage (reference only), and return to the de-energized position at a voltage no less than the minimum dropout voltage.
- 4/ Diode Code is not applicable.

Table 5. Coil Data and Operating Characteristics of Relays with Diode for Coil Transient Suppression.

Coil voltage (V d.c.) <u>2/</u>		Room ambient temperature (+25 °C)				Over temperature range			Coil transient suppression diode code
Rated	Max	Coil resis- tance (Ω) ± 10 %	Pickup voltage (V d.c.) max <u>3/</u>	Hold voltage (V d.c.) max <u>3/</u>	Dropout voltage (V d.c.) min <u>3/</u>	Pickup voltage (V d.c.) max <u>3/</u>	Hold voltage (V d.c.) max <u>3/</u>	Dropout voltage (V d.c.) min <u>3/</u>	
5.0	5.8	33	3.38	1.25	0.27	4.6	2.3	0.14	D
6.0	8.0	44	4.05	1.5	0.32	5.5	3.2	0.18	D
9.0	12.0	125	6.1	2.3	0.48	8.2	4.9	0.35	D
12.0	16.0	215	8.1	3.0	0.65	11.0	6.5	0.41	D
18.0	24.0	470	12.2	4.5	0.97	16.5	10.0	0.59	D
26.5	32.0	1050	16.3	6.0	1.3	22.0	13.0	0.89	D

Notes to Table 5:

1. Each relay possesses high level and low level capabilities. However, relays previously tested or used above 10 mA resistive at 6 V d.c. maximum or peak a.c. open circuit are not recommended for subsequent use in low level applications.
- 2/ The use of any coil voltage other than the rated coil voltage will affect the electrical and dynamic characteristics of the relay.
- 3/ Relay contacts shall transfer to the energized position at a voltage no greater than the maximum pickup voltage, hold in the energized position when the coil voltage is reduced from rated coil voltage to the maximum hold voltage (reference only), and return to the de-energized position at a voltage no less than the minimum dropout voltage.

Table 6. Coil Data and Operating Characteristics of Relays with Diode(s) for Coil Transient Suppression and Polarity Reversal Protection.

Coil voltage (V d.c.) <u>2/</u>		Room ambient temperature (+25 °C)						Over temperature range			Coil transient suppression and polarity reversal protection diode code
		Coil resistance (ref. only) (Ω) <u>3/</u>	Coil circuit current (mA) <u>3/</u>		Pickup voltage (V d.c.) max <u>4/</u>	Hold voltage (V d.c.) max <u>4/</u>	Dropout voltage (V d.c.) min <u>4/</u>	Pickup voltage (V d.c.) max <u>4/</u>	Hold voltage (V d.c.) max <u>4/</u>	Dropout voltage (V d.c.) min <u>4/</u>	
Rated	Max		Max	Min							
5.0	5.8	33	126.4	92.8	3.38	1.9	0.27	4.6	2.3	0.14	DD
6.0	8.0	44	122.6	90.4	4.05	2.2	0.32	5.5	3.2	0.18	DD
9.0	12.0	125	73.4	54.3	6.1	3.3	0.48	8.2	4.9	0.35	DD
12.0	16.0	215	59.4	37.8	8.1	3.8	0.65	11.0	6.5	0.41	DD
18.0	24.0	470	42.0	31.3	12.2	5.3	0.97	16.5	10.0	0.59	DD
26.5	32.0	1050	28.3	21.3	16.3	6.8	1.3	22.0	13.0	0.89	DD

Notes to Table 6:

1. Each relay possesses high level and low level capabilities. However, relays previously tested or used above 10 mA resistive at 6 V d.c. maximum or peak a.c. open circuit are not recommended for subsequent use in low level applications.
- 2/ The use of any coil voltage other than the rated coil voltage will affect the electrical and dynamic characteristics of the relay.
- 3/ Coil resistance is not directly measurable at relay terminals; coil current shall be measured in lieu of coil resistance.
- 4/ Relay contacts shall transfer to the energized position at a voltage no greater than the maximum pickup voltage, hold in the energized position when the coil voltage is reduced from rated coil voltage to the maximum hold voltage (reference only), and return to the de-energized position at a voltage no less than the minimum dropout voltage.

2.5. Mounting Variants.

See Table 7 and Appendix A herein.

Table 7. Mounting Variants.

Mounting code	Type of mounting
No Code	Without mounting
X	Ground pin at position X
Y	Ground pin at position Y
Z	Ground pin at position Z
XY	Ground pins at positions X and Y
XZ	Ground pins at positions X and Z
YZ	Ground pins at positions Y and Z
M4	M4 spacer pad
XM4	Ground pin at position X with M4 spacer pad
YM4	Ground pin at position Y with M4 spacer pad
ZM4	Ground pin at position Z with M4 spacer pad
M	M spreader pad
YM	Ground pin at position Y with M spreader pad
ZM	Ground pin at position Z with M spreader pad
YZM	Ground pin at positions Y and Z with M spreader pad
M2	M2 spreader pad
XM3	Ground pin at positions X with M3 spreader pad
XYM3	Ground pin at positions X and Y with M3 spreader pad
XZM3	Ground pin at positions X and Z with M3 spreader pad
XYZM3	Ground pin at positions X, Y and Z with M3 spreader pad

Notes to Table 6:

- Optional ground pins are non-insulated case grounds. See Figure 3 for available ground pin positions.
- M4 spacer pad is a polyester film and is attached to the relay.
- M, M2 and M3 spreader pads are made from diallyl phthalate and are attached to the relay.

2.6. **Termination Variants.**

See Table 8 and Appendix A herein.

Table 8. Termination Variants.

Termination variant	Length of terminals	Finish <u>1/</u>
No Code	0.750 in. min. (19.05 mm)	Gold plated or solder coated
G	0.750 in. min. (19.05 mm)	Gold plated
Q	0.750 in. min. (19.05 mm)	Solder coated
S	0.187 ± 0.010 in. (4.75 ± 0.25 mm)	Gold plated or solder coated
SG	0.187 ± 0.010 in. (4.75 ± 0.25 mm)	Gold plated
SQ	0.187 ± 0.010 in. (4.75 ± 0.25 mm)	Solder coated
W	1.50 in. min (38.10 mm)	Gold plated or solder coated
WG	1.50 min (38.10 mm)	Gold plated
WQ	1.50 min (38.10 mm)	Solder coated

Notes to Table 7:
1/ Maximum lead diameter after solder coating is 0.020 in. (0.508 mm), except at the free end of the lead. Maximum lead diameter at the free end of the lead after solder coating is 0.025 in. (0.635 mm).

Figure 3. Ground Pin Positions.

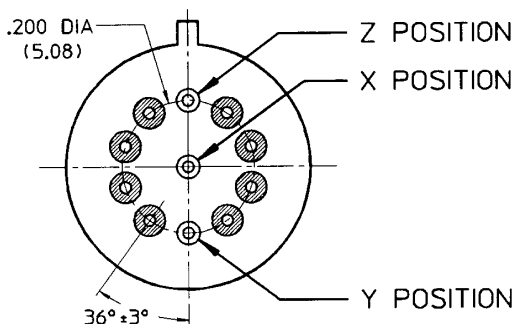

2.7. Testing Selection ID Designator.

The Testing Section ID Designator is an alphanumeric field that represents the combination of manufacturing and/or screening variants indicated below that are specified by the Orderer. Each combination of manufacturing and/or screening variants has a unique ID designator which is part of the Part Number (see 2.2). It allows the Orderer to select from specified manufacturing and/or screening variants based on program requirements.

2.7.1. Manufacturing Variants.

Prior to encapsulation, when specified (see TR-HIREL-1/Supplement 1), the relays shall be subjected to the tests/inspections specified in Table 9.

2.7.2. Screening Variants.

When specified (see TR-HIREL-1/Supplement 1), the relays shall be tested for the following attributes or shall be subjected to the tests/inspections of Table 10 as part of Quality Conformance Inspection. Refer to see TR-HIREL-1/Supplement 1 for a further breakdown of Lot Acceptance Test Level 2 and 1.

Table 9. Manufacturing Variants.

Test	Requirement paragraph in TR-HIREL-1	Test method paragraph in TR-HIREL-1
Small Particle Inspection	3.1	4.11.2

Table 10. Screening Variants.

Test	Requirement paragraph in TR-HIREL-1	Test method paragraph in TR-HIREL-1
Solderability	3.6.2	4.11.4
Vibration (random)	3.6.6	4.11.11.2
Vibration miss test	3.6.7	4.11.12
Particle impact noise detection	3.6.21	4.11.23
Contact bounce time	3.4.2.1	4.11.8.5.2
Contact stabilization time	3.4.2.2	4.11.8.5.3
Lot Acceptance Tests (Level 3)	3.1	4.10.3
Lot Acceptance Tests (Level 2)	3.1	4.10.3
Lot Acceptance Tests (Level 1)	3.1	4.10.3

2.8. Environmental Data.

The relays shall withstand the environmental tests as specified in Table 11.

Table 11. Environmental Tests.

Test	Requirement paragraph in TR-HIREL-1	Test method paragraph in TR-HIREL-1	Details and exceptions
Solderability	3.6.2	4.11.4	
Thermal shock	3.6.4	4.12.9	
Shock (specified pulse)	3.6.5	4.11.10	See 2.8.1.
Vibration (sinusoidal)	3.6.6	4.12.11.1	See 2.8.2.
Vibration (resonant beam)			See 2.8.3.
Vibration (random)	3.6.6	4.12.11.2	
Terminal strength	3.6.8	4.11.20	
Coil life	3.6.9	4.11.21	
Resistance to soldering heat	3.6.10	4.11.17	
Salt atmosphere (corrosion)	3.6.11	4.11.13	Performance requirement.
Resistance to solvents	3.6.16	4.11.16	

2.8.1. Shock.
2.8.1.1. Operating Shock.

As indicated in TR-HIREL-1 except as follows:

- a) Test Condition: G level shall be 150G, half sine, duration 11 milliseconds.

2.8.1.2. Non-Operating Shock.

As indicated in TR-HIREL-1 except as follows:

- a) Test Condition: G level shall be 750G, half sine, duration 0.5 milliseconds.
- b) Coil Energization Conditions: Relays shall be subjected to a total of 12 shock blows, 3 in each direction of the following axes: one is the cylindrical axis, the other is an axis parallel to the direction of the tab on the case and at right angles to the cylindrical axis. Coil voltage shall not be applied during these shock pulses.

- c) Measurements during test: Contact monitoring is not applicable.

2.8.2. Vibration (sinusoidal).

As indicated in TR-HIREL-1 except as follows:

- a) Test Condition E, except vibration level is the lesser of 0.200 inch double amplitude from 10-100 Hz, 100G from 100 to 1000Hz and 50G from 1,000 to 2,000Hz. The sweep rate shall be ½ octave per minute.
- b) Coil Energization conditions: Coil de-energized. The relays shall be subjected to three scans, one in each of the axes indicated in 2.8.1.2b herein.

c) Screening and Electrical Measurements Vibration Test.

The relays shall be subjected to three scans in each of the axes indicated in 2.8.1.2b herein at a rate of 1 octave per minute. The vibration level shall be 0.1 inch double amplitude from 10 to 100 Hz and 50G from 100 to 3000 Hz.

2.8.3. Vibration (resonant beam).

The relays shall be subjected to the following test:

- a) Mounting method: Rigidly mounted by normal mounting means.
- b) Test condition: Relays shall be vibrated in the axis parallel to contact motion as indicated below for 10 seconds minimum at each of the following frequencies:

Vibration level	Frequency (Hz) ± 5 Hz	Acceleration (G's peak)
I	140	250
II	170	350
III	200	380

- c) Coil Energization: Coil de-energized.
- d) Measurements during vibration: Contacts shall be monitored by a suitable means. The test circuit shall verify that no opening of closed contacts in excess of 10 μs and no false closure or abnormal bridging of open contacts occurs in excess of 1 μs. The contact load shall be 10 mA maximum at 6 V d.c. maximum or peak a.c.

3. MARKING

Marking on the relay includes Teledyne Relays' Part Number (see 2.2), Lot Number, circuit diagram, Teledyne Relays' name, serial number and contact current rating. The circuit diagram as marked on the relay is the terminal view.

4. QUALITY ASSURANCE

Quality assurance provisions are as specified in TR-HIREL-1. The following details shall apply:

4.1. Final Production Tests.

See Table 12.

4.2. Screening and Electrical Measurements.

See Table 13.

4.3. Lot Acceptance Tests (when specified, see TR-HIREL-1/Supplement 1).

See Tables 14, 15, 16.

Table 12. Final Production Tests. 1/

Inspection	Requirement in TR-HIREL-1	Test method in TR-HIREL-1	Details and exceptions in this spec	Diode Codes		
				None	D	DD
1. Verification of precap inspection, customer source inspection - precap inspection, Marking/serialization	Ref.: 3.6.18, 3.6.17	Ref. 4.11.1.1	2.2, 3.0	✓	✓	✓
2. Verification of small particle inspection (when specified)	3.1	4.11.2	2.7.1	✓	✓	✓
3. Room temperature electrical measurements <u>2/</u>						
a) Coil resistance	3.5.4	4.11.8.2	2.4.3	✓	✓	
b) Coil current	3.5.5	4.11.8.3	2.4.3			✓
c) Insulation resistance	3.5.1	4.11.6	2.4.1	✓	✓	✓
d) Dielectric withstanding voltage (atmospheric pressure)	3.5.2	4.11.7	2.4.2	✓	✓	✓
e) Static contact resistance	3.4.1.1	4.11.8.5.1	2.3.2	✓	✓	✓
f) Pickup voltage	3.5.3.1	4.11.8.1.1	2.4.3	✓	✓	✓
g) Dropout voltage	3.5.3.3	4.11.8.1.3	2.4.3	✓	✓	✓
h) Operate and release time	3.5.6	4.11.8.4	2.4.4	✓	✓	✓
i) Operate and release contact bounce time (when specified)	3.4.2.1	4.11.8.5.2	2.3.3, 2.7.2	✓	✓	✓
j) Operate and release contact stabilization time (when specified)	3.4.2.2	4.11.8.5.3	2.3.4, 2.7.2	✓	✓	✓
k) Coil transient suppression	3.5.7.1	4.11.8.6.1	2.4.5.1		✓	✓
l) Block integrity	3.5.7.2	4.11.8.6.2	2.4.5.2			✓
4. Solderability <u>3/</u>	3.6.2	4.11.4	2.7.2, 2.8	✓	✓	✓
5. Seal	3.6.3	4.11.5	2.1.5	✓	✓	✓
6. Visual inspection, external <u>4/</u>	3.6.18	4.11.1.2	2.1.3, 2.1.4, 2.1.6, 2.2	✓	✓	✓

Notes to Table 12:

1/ 100% inspection applies, unless otherwise noted. For 100 % inspection, discard all failed relays.

2/ Test sequence is optional.

3/ Perform on 2 relays from each lot. Failed relays resulting from Room Temperature Electrical Measurements may be used for test.

4/ Physical dimensions and weight shall be measured on two sample units per lot.

Table 13. Screening and Electrical Measurements. 1/

Inspection	Requirement in TR-HIREL-1	Test method in TR-HIREL-1	Details and exceptions in this spec	Diode Codes		
				None	D	DD
1. Vibration, sinusoidal	3.6.6	4.11.11.1	2.8	✓	✓	✓
2. Vibration, resonant beam			2.8	✓	✓	✓
3. Vibration, random (when specified)	3.6.6	4.11.11.2	2.7.2, 2.8	✓	✓	✓
4. Vibration miss test (when specified)	3.6.7	4.11.12	2.7.2	✓	✓	✓
5. Particle impact noise detection (PIND) test (when specified)	3.6.21	4.11.23	2.7.2	✓	✓	✓
6. Internal moisture	3.6.1	4.11.3.1		✓	✓	✓
7. Thermal cycle/Miss test	3.6.19	4.11.3.2				
First four hot/cold cycles:						
a) Coil continuity		4.11.3.2.1		✓	✓	✓
Fifth hot/cold cycle:						
b) High temperature soak		4.11.3.2.1		✓	✓	✓
c) High temperature electrical measurements 2/		4.11.3.2.1				
i. Insulation resistance	3.5.1	4.11.6	2.4.1	✓	✓	✓
ii. Pickup voltage	3.5.3.1	4.11.8.1.1	2.4.3	✓	✓	✓
iii. Dropout voltage	3.5.3.3	4.11.8.1.3	2.4.3	✓	✓	✓
iv. Static contact resistance	3.4.1.1	4.11.8.5.1	2.3.2	✓	✓	✓
v. Operate and release time	3.5.6	4.11.8.4	2.4.4	✓	✓	✓
vi. Operate and release contact bounce time	3.4.2.1	4.11.8.5.2	2.3.3	✓	✓	✓
d) High temperature Miss test	3.6.1	4.11.3.2.1, 4.11.3.2.2		✓	✓	✓
e) Low temperature soak		4.11.3.2.1		✓	✓	✓
f) Low temperature electrical measurements 2/		4.11.3.2.1				
i. Pickup voltage	3.5.3.1	4.11.8.1.1	2.4.3	✓	✓	✓
ii. Dropout voltage	3.5.3.3	4.11.8.1.3	2.4.3	✓	✓	✓
iii. Static contact resistance	3.4.1.1	4.11.8.5.1	2.3.2	✓	✓	✓
iv. Operate and release time	3.5.6	4.11.8.4	2.4.4	✓	✓	✓
v. Operate and release contact bounce time	3.4.2.1	4.11.8.5.2	2.3.3	✓	✓	✓

See notes at end of Table.

Table 12. Screening and Electrical Measurements (cont'd). 1/

Inspection	Requirement in TR-HIREL-1	Test method in TR-HIREL-1	Details and exceptions in this spec	Diode Codes		
				None	D	DD
7. Thermal cycle/Miss test (cont'd)						
g) Low temperature Miss test	3.6.1	4.11.3.2.1, 4.11.3.2.2		✓	✓	✓
h) Stabilize at room ambient temperature		4.11.3.2.1		✓	✓	✓
i) Room temperature Miss test	3.6.1	4.11.3.2.1, 4.11.3.2.2		✓	✓	✓
8. Room temperature electrical measurements 2/						
a) Coil resistance	3.5.4	4.11.8.2	2.4.3	✓	✓	
b) Coil current	3.5.5	4.11.8.3	2.4.3			✓
c) Insulation resistance	3.5.1	4.11.6	2.4.1	✓	✓	✓
d) Dielectric withstanding voltage (atmospheric pressure)	3.5.2	4.11.7	2.4.2	✓	✓	✓
e) Static contact resistance	3.4.1.1	4.11.8.5.1	2.3.2	✓	✓	✓
f) Pickup voltage	3.5.3.1	4.11.8.1.1	2.4.3	✓	✓	✓
g) Dropout voltage	3.5.3.3	4.11.8.1.3	2.4.3	✓	✓	✓
h) Operate and release time	3.5.6	4.11.8.4	2.4.4	✓	✓	✓
i) Operate and release contact bounce time (when specified)	3.4.2.1	4.11.8.5.2	2.3.3, 2.7.2	✓	✓	✓
j) Operate and release contact stabilization time (when specified)	3.4.2.2	4.11.8.5.3	2.3.4, 2.7.2	✓	✓	✓
k) Coil transient suppression	3.5.7.1	4.11.8.6.1	2.4.5.1		✓	✓
l) Block integrity	3.5.7.2	4.11.8.6.2	2.4.5.2			✓
9. Seal	3.6.3	4.11.5	2.1.5	✓	✓	✓
10. Radiographic inspection	3.6.20	4.11.22		✓	✓	✓
11. Visual inspection, external 4/	3.6.18	4.11.1.2	2.1.3, 2.1.6, 2.2	✓	✓	✓
12. Check for lot failure		4.8		✓	✓	✓

Notes to Table 13:

1/ Inspection sample 100 % unless otherwise noted; discard all failed relays.

2/ Test sequence is optional.

3. Ground pin attachment, spacer/spreader pad attachment, lead trimming, or lead solder coating processes may be performed before, during, or after Screening and Electrical Measurements. An electrical inspection, and/or seal test, and/or external visual and mechanical inspection, as applicable, shall follow any of these processes.

4/ The header glass criteria is not applicable to relays supplied with attached spreader pads.

Table 14. Lot Acceptance Test 3. 1/

Inspection	Requirement in TR-HIREL-1	Test Method in TR-HIREL-1	Details and exceptions in this spec	Diode Codes		
				None	D	DD
1. Room temperature electrical measurements <u>3/</u>						
a) Coil resistance	3.5.4	4.11.8.2	2.4.3	✓	✓	
b) Coil current	3.5.5	4.11.8.3	2.4.3			✓
c) Insulation resistance	3.5.1	4.11.6	2.4.1	✓	✓	✓
d) Dielectric withstanding voltage (atmospheric pressure)	3.5.2	4.11.7	2.4.2	✓	✓	✓
e) Static contact resistance	3.4.1.1	4.11.8.5.1	2.3.2	✓	✓	✓
f) Pickup voltage	3.5.3.1	4.11.8.1.1	2.4.3	✓	✓	✓
g) Dropout voltage	3.5.3.3	4.11.8.1.3	2.4.3	✓	✓	✓
h) Operate and release time	3.5.6	4.11.8.4	2.4.4	✓	✓	✓
i) Operate and release contact bounce time (when specified)	3.4.2.1	4.11.8.5.2	2.3.3, 2.7.2	✓	✓	✓
j) Operate and release contact stabilization time (when specified)	3.4.2.2	4.11.8.5.3	2.3.4, 2.7.2	✓	✓	✓
k) Coil transient suppression	3.5.7.1	4.11.8.6.1	2.4.5.1		✓	✓
l) Block integrity	3.5.7.2	4.11.8.6.2	2.4.5.2			✓
2. Seal	3.6.3	4.11.5	2.1.5	✓	✓	✓
3. Visual inspection, external <u>3/</u>	3.6.18	4.11.1.2	2.1.3, 2.1.6, 2.2	✓	✓	✓
4. Check for lot failure		4.8		✓	✓	✓
Notes to Table 14:						
<u>1/</u> See TR-HIREL-1, paragraph 4.10.3.3 and 2.7.2 herein.						
<u>2/</u> Test sequence is optional.						
<u>3/</u> The header glass criteria is not applicable to relays supplied with attached spreader pads.						

Table 15. Lot Acceptance Test 2. 1/

Inspection	Requirement in TR-HIREL-1	Test method in TR-HIREL-1	Details and exceptions in this spec	Diode Codes		
				None	D	DD
Group I			2.7.2			
1. Life <u>1</u> /	3.6.13	4.11.19	2.3.1, 2.7.2	✓	✓	✓
2. Room temperature electrical measurements <u>2</u> /						
a) Coil resistance	3.5.4	4.11.8.2	2.4.3	✓	✓	
b) Coil current	3.5.5	4.11.8.3	2.4.3			✓
c) Insulation resistance	3.5.1	4.11.6	2.4.1	✓	✓	✓
d) Dielectric withstanding voltage (atmospheric pressure)	3.5.2	4.11.7	2.4.2	✓	✓	✓
e) Static contact resistance	3.4.1.1	4.11.8.5.1	2.3.2	✓	✓	✓
f) Pickup voltage	3.5.3.1	4.11.8.1.1	2.4.3	✓	✓	✓
g) Dropout voltage	3.5.3.3	4.11.8.1.3	2.4.3	✓	✓	✓
h) Operate and release time	3.5.6	4.11.8.4	2.4.4	✓	✓	✓
i) Operate and release contact bounce time (when specified)	3.4.2.1	4.11.8.5.2	2.3.3, 2.7.2	✓	✓	✓
j) Operate and release contact stabilization time (when specified)	3.4.2.2	4.11.8.5.3	2.3.4, 2.7.2	✓	✓	✓
k) Coil transient suppression	3.5.7.1	4.11.8.6.1	2.4.5.1		✓	✓
l) Block integrity	3.5.7.2	4.11.8.6.2	2.4.5.2			✓
3. Visual inspection, external <u>3</u> /	3.6.18	4.11.1.2	2.1.3, 2.1.6, 2.2	✓	✓	✓
4. Check for lot failure		4.8		✓	✓	✓

See notes at end of Table.

Table 15. Lot Acceptance Test 2 (cont'd). 1/

Inspection	Requirement in TR-HIREL-1	Test method in TR-HIREL-1	Details and exceptions in this spec	Diode Codes		
				None	D	DD
Group II			2.7.2			
1. Intermediate current <u>1/</u>	3.6.14	4.11.14	2.3.1, 2.7.2	✓	✓	✓
2. Room temperature electrical measurements <u>2/</u>						
a) Coil resistance	3.5.4	4.11.8.2	2.4.3	✓	✓	
b) Coil current	3.5.5	4.11.8.3	2.4.3			✓
c) Insulation resistance	3.5.1	4.11.6	2.4.1	✓	✓	✓
d) Dielectric withstanding voltage (atmospheric pressure)	3.5.2	4.11.7	2.4.2	✓	✓	✓
e) Static contact resistance	3.4.1.1	4.11.8.5.1	2.3.2	✓	✓	✓
f) Pickup voltage	3.5.3.1	4.11.8.1.1	2.4.3	✓	✓	✓
g) Dropout voltage	3.5.3.3	4.11.8.1.3	2.4.3	✓	✓	✓
h) Operate and release time	3.5.6	4.11.8.4	2.4.4	✓	✓	✓
i) Operate and release contact bounce time (when specified)	3.4.2.1	4.11.8.5.2	2.3.3, 2.7.2	✓	✓	✓
j) Coil transient suppression	3.5.7.1	4.11.8.6.1	2.4.5.1		✓	✓
k) Block integrity	3.5.7.2	4.11.8.6.2	2.4.5.2			✓
3. Visual inspection, external <u>3/</u>	3.6.18	4.11.1.2	2.1.3, 2.1.6, 2.2	✓	✓	✓
4. Check for lot failure		4.8		✓	✓	✓

See notes at end of Table.

Table 15. Lot Acceptance Test 2 (cont'd). 1/

Inspection	Requirement in TR-HIREL-1	Test method in TR-HIREL-1	Details and exceptions in this spec	Diode Codes		
				None	D	DD
Group III			2.7.2			
1. Overload (highest dc resistive load) <u>1/</u>	3.6.12	4.11.18	2.3.1, 2.7.2	✓	✓	✓
2. Room temperature electrical measurements <u>2/</u>						
a) Coil resistance	3.5.4	4.11.8.2	2.4.3	✓	✓	
b) Coil current	3.5.5	4.11.8.3	2.4.3			✓
c) Insulation resistance	3.5.1	4.11.6	2.4.1	✓	✓	✓
d) Dielectric withstanding voltage (atmospheric pressure)	3.5.2	4.11.7	2.4.2	✓	✓	✓
e) Static contact resistance	3.4.1.1	4.11.8.5.1	2.3.2	✓	✓	✓
f) Pickup voltage	3.5.3.1	4.11.8.1.1	2.4.3	✓	✓	✓
g) Dropout voltage	3.5.3.3	4.11.8.1.3	2.4.3	✓	✓	✓
h) Operate and release time	3.5.6	4.11.8.4	2.4.4	✓	✓	✓
i) Operate and release contact bounce time (when specified)	3.4.2.1	4.11.8.5.2	2.3.3, 2.7.2	✓	✓	✓
j) Coil transient suppression	3.5.7.1	4.11.8.6.1	2.4.5.1		✓	✓
k) Block integrity	3.5.7.2	4.11.8.6.2	2.4.5.2			✓
3. Visual Inspection, external <u>3/</u>	3.6.18	4.11.1.2	2.1.3, 2.1.6, 2.2	✓	✓	✓
4. Check for lot failure		4.8		✓	✓	✓

See notes at end of Table.

Table 15. Lot Acceptance Test 2 (cont'd). 1/

Inspection	Requirement in TR-HIREL-1	Test method in TR-HIREL-1	Details and exceptions in this spec	Diode Codes		
				None	D	DD
Group IV			2.7.2			
1. Mechanical life <u>1/</u>	3.6.15	4.11.15	2.3.1, 2.7.2	✓	✓	✓
2. Room temperature electrical measurements <u>2/</u>						
a) Coil resistance	3.5.4	4.11.8.2	2.4.3	✓	✓	
b) Coil current	3.5.5	4.11.8.3	2.4.3			✓
c) Insulation resistance	3.5.1	4.11.6	2.4.1	✓	✓	✓
d) Dielectric withstanding voltage (atmospheric pressure)	3.5.2	4.11.7	2.4.2	✓	✓	✓
e) Static contact resistance	3.4.1.1	4.11.8.5.1	2.3.2	✓	✓	✓
f) Pickup voltage	3.5.3.1	4.11.8.1.1	2.4.3	✓	✓	✓
g) Dropout voltage	3.5.3.3	4.11.8.1.3	2.4.3	✓	✓	✓
h) Operate and release time	3.5.6	4.11.8.4	2.4.4	✓	✓	✓
i) Operate and release contact bounce time (when specified)	3.4.2.1	4.11.8.5.2	2.3.3, 2.7.2	✓	✓	✓
j) Operate and release contact stabilization time (when specified)	3.4.2.2	4.11.8.5.3	2.3.4, 2.7.2	✓	✓	✓
k) Coil transient suppression	3.5.7.1	4.11.8.6.1	2.4.5.1		✓	✓
l) Block integrity	3.5.7.2	4.11.8.6.2	2.4.5.2			✓
3. Visual Inspection, external <u>3/</u>	3.6.18	4.11.1.2	2.1.3, 2.1.6, 2.2	✓	✓	✓
4. Check for lot failure		4.8		✓	✓	✓
Notes to Table 15:						
1/ See TR-HIREL-1, paragraph 4.10.3.3 and 2.7.2 herein.						
2/ Test sequence is optional.						
3/ The header glass criteria is not applicable.						
4. Post-life operating characteristics, operate and release time, and contact dynamic characteristics, as applicable, are allowed to have a 10% variance from the initial allowable values.						

Table 16. Lot Acceptance Test 1. 1/

Inspection	Requirement in TR-HIREL-1	Test method in TR-HIREL-1	Details and exceptions in this spec	Diode Codes		
				None	D	DD
Group I			2.7.2			
1. Thermal shock	3.6.4	4.11.9		✓	✓	✓
2. Shock (specified pulse)	3.6.5	4.11.10	2.8	✓	✓	✓
3. Vibration (sinusoidal and random)	3.6.6	4.11.11	2.8	✓	✓	✓
4. Terminal strength	3.6.8	4.11.20	2.8	✓	✓	✓
5. Room temperature electrical measurements <u>2</u> /						
a) Coil resistance	3.5.4	4.11.8.2	2.4.3	✓	✓	
b) Coil current	3.5.5	4.11.8.3	2.4.3			✓
c) Insulation resistance	3.5.1	4.11.6	2.4.1	✓	✓	✓
d) Dielectric withstanding voltage (atmospheric pressure)	3.5.2	4.11.7	2.4.2	✓	✓	✓
e) Static contact resistance	3.4.1.1	4.11.8.5.1	2.3.2	✓	✓	✓
f) Pickup voltage	3.5.3.1	4.11.8.1.1	2.4.3	✓	✓	✓
g) Dropout voltage	3.5.3.3	4.11.8.1.3	2.4.3	✓	✓	✓
h) Operate and release time	3.5.6	4.11.8.4	2.4.4	✓	✓	✓
i) Operate and release contact bounce time (when specified)	3.4.2.1	4.11.8.5.2	2.3.3, 2.7.2	✓	✓	✓
j) Operate and release contact stabilization time (when specified)	3.4.2.2	4.11.8.5.3	2.3.4, 2.7.2	✓	✓	✓
k) Coil transient suppression	3.5.7.1	4.11.8.6.1	2.4.5.1		✓	✓
l) Block integrity	3.5.7.2	4.11.8.6.2	2.4.5.2			✓
6. Seal	3.6.3	4.11.5	2.1.5	✓	✓	✓
7. Visual inspection, external <u>3</u> /	3.6.18	4.11.1.2	2.1.3, 2.1.6, 2.2	✓	✓	✓
8. Check for lot failure		4.8		✓	✓	✓

See notes at end of Table.

Table 16. Lot Acceptance Test 1 (cont'd). 1/

Inspection	Requirement in TR-HIREL-1	Test method in TR-HIREL-1	Details and exceptions in this spec	Diode Codes		
				None	D	DD
Group II			2.7.2			
1. Coil life	3.6.9	4.11.21	2.8	✓	✓	✓
2. Resistance to solvents	3.6.16	4.11.16	2.8	✓	✓	✓
3. Resistance to soldering heat	3.6.10	4.11.17	2.8	✓	✓	✓
4. Room temperature electrical measurements <u>2/</u>						
a) Coil resistance	3.5.4	4.11.8.2	2.4.3	✓	✓	
b) Coil current	3.5.5	4.11.8.3	2.4.3			✓
c) Insulation resistance	3.5.1	4.11.6	2.4.1	✓	✓	✓
d) Dielectric withstanding voltage (atmospheric pressure)	3.5.2	4.11.7	2.4.2	✓	✓	✓
e) Static contact resistance	3.4.1.1	4.11.8.5.1	2.3.2	✓	✓	✓
f) Pickup voltage	3.5.3.1	4.11.8.1.1	2.4.3	✓	✓	✓
g) Dropout voltage	3.5.3.3	4.11.8.1.3	2.4.3	✓	✓	✓
h) Operate and release time	3.5.6	4.11.8.4	2.4.4	✓	✓	✓
i) Operate and release contact bounce time (when specified)	3.4.2.1	4.11.8.5.2	2.3.3, 2.7.2	✓	✓	✓
j) Operate and release contact stabilization time (when specified)	3.4.2.2	4.11.8.5.3	2.3.4, 2.7.2	✓	✓	✓
k) Coil transient suppression	3.5.7.1	4.11.8.6.1	2.4.5.1		✓	✓
l) Block integrity	3.5.7.2	4.11.8.6.2	2.4.5.2			✓
5. Visual inspection, external <u>3/</u>	3.6.18	4.11.1.2	2.1.3, 2.1.6, 2.2	✓	✓	✓
6. Check for lot failure		4.8		✓	✓	✓

Notes to Table 16:

1/ See TR-HIREL-1 paragraph 4.10.3.3 and 2.7.2 herein.

2/ Test sequence is optional.

3/ The header glass criteria is not applicable.

4 Post-life operating characteristics, operate and release time, and contact dynamic characteristics, as applicable, are allowed to have a 10% variance from the initial allowable values.

5. GENERAL NOTES.

- a) Reverse polarity on the coil terminals of relays supplied with internal diode for coil transient suppression (without polarity reversal protection) will destroy the diode.
- b) When used in applications at high level loads, surge current protection is recommended.

Appendix A. Mounting and Termination Variants.

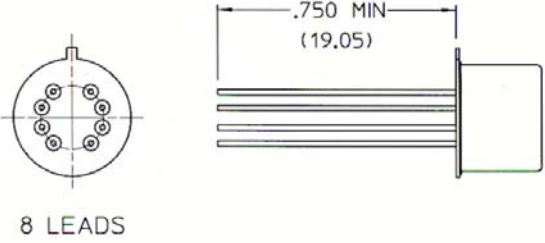
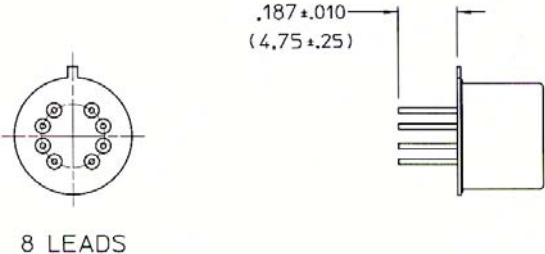
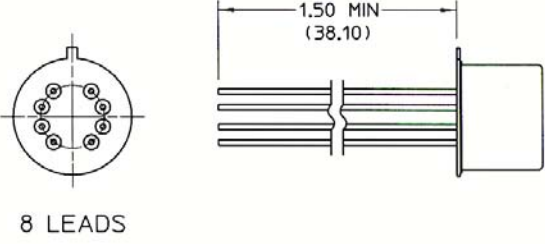
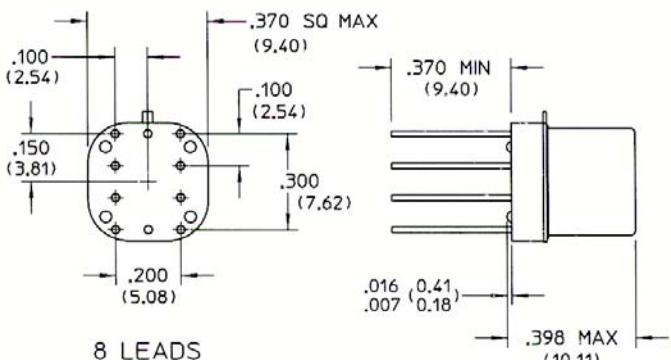
Mounting	Termination	Configuration
No Code	No Code G Q	 <p>8 LEADS</p>
No Code	S SG SQ	 <p>8 LEADS</p>
No Code	W WG WQ	 <p>8 LEADS</p>
M	No Code G Q	 <p>8 LEADS</p>



Appendix A. Mounting and Termination Variants (Cont'd).

Mounting	Termination	Configuration
M2	No Code G Q	<p>8 LEADS</p>
M4	No Code G Q	<p>8 LEADS</p>
M4	S SG SQ	<p>8 LEADS</p>
X	No Code G Q	<p>9 LEADS</p>

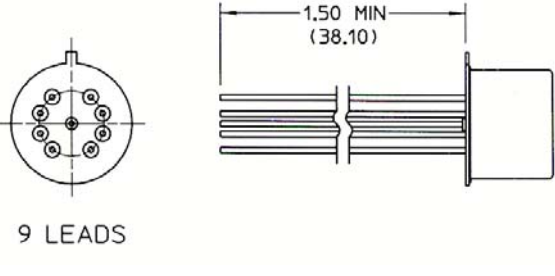
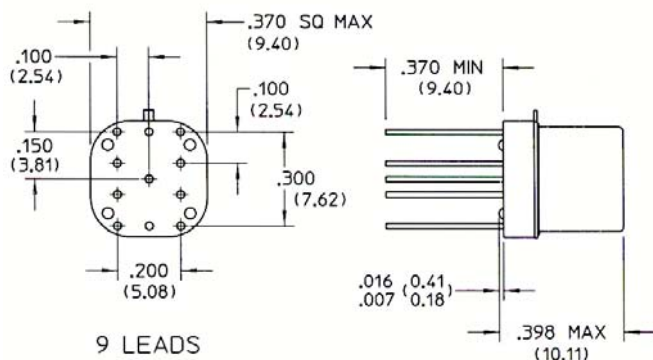
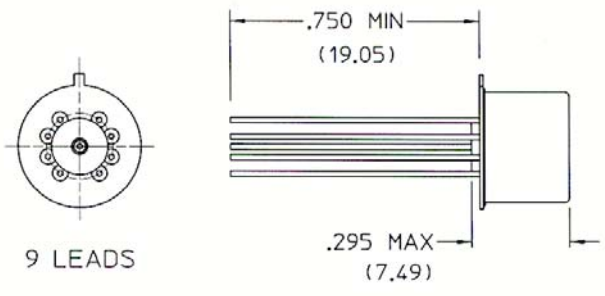

Appendix A. Mounting and Termination Variants (Cont'd).

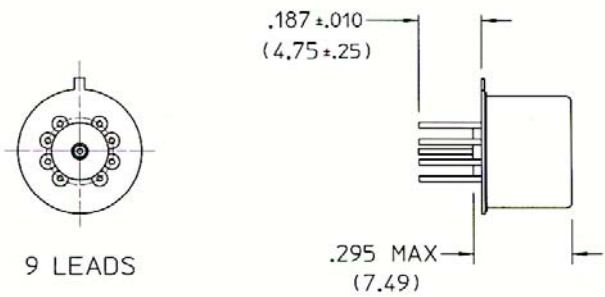
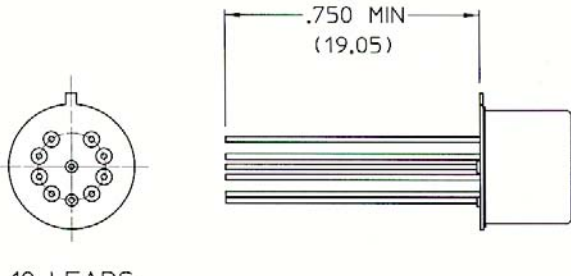
Mounting	Termination	Configuration
X	S SG SQ	 <p>9 LEADS</p>
X	W WG WQ	 <p>9 LEADS</p>
XM3	No Code G Q	 <p>9 LEADS</p>
XM4	No Code G Q	 <p>9 LEADS</p>

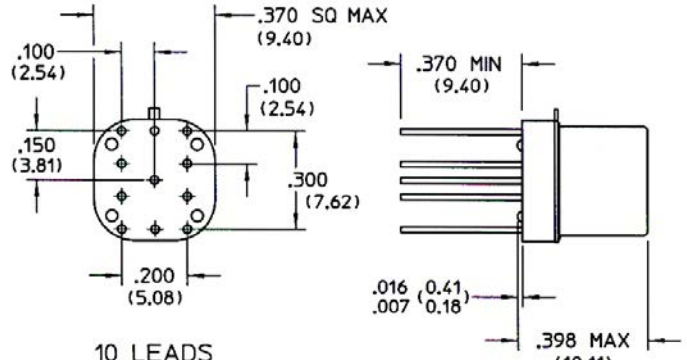
Appendix A. Mounting and Termination Variants (Cont'd).

Mounting	Termination	Configuration
XM4	S SG SQ	 <p>9 LEADS</p>
XY	No Code G Q	 <p>10 LEADS</p>
XY	S SG SQ	 <p>10 LEADS</p>
XYM3	No Code G Q	 <p>10 LEADS</p>

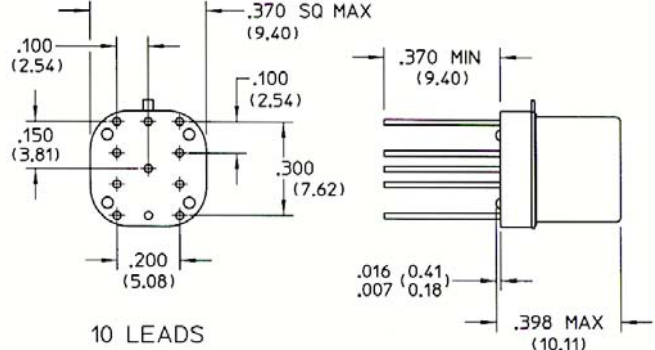

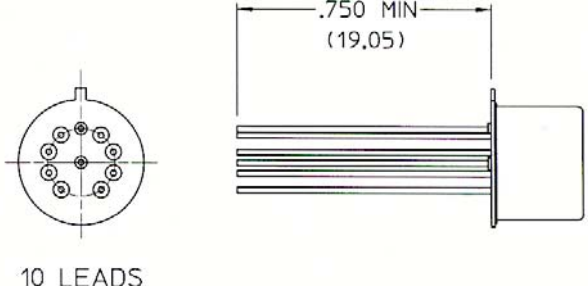
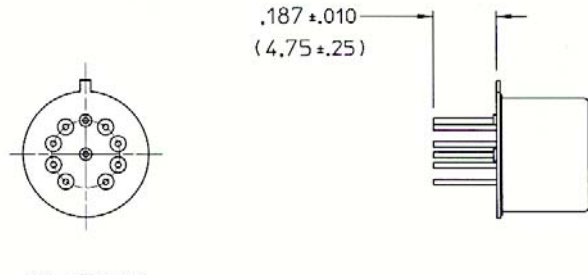
Appendix A. Mounting and Termination Variants (Cont'd).

Mounting	Termination	Configuration
XZM3	No Code G Q	 <p>10 LEADS</p>
XYZM3	No Code G Q	 <p>11 LEADS</p>
XZ	No Code G Q	 <p>10 LEADS</p>
XZ	S SG SQ	 <p>10 LEADS</p>

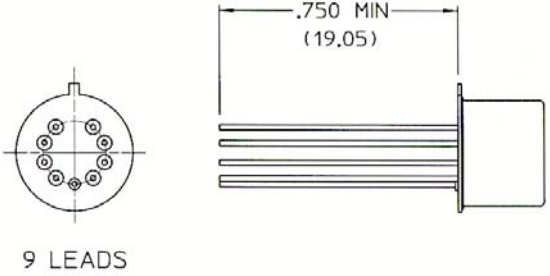
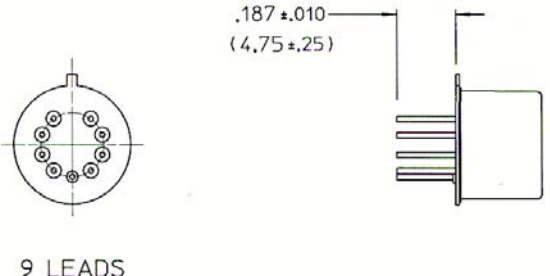
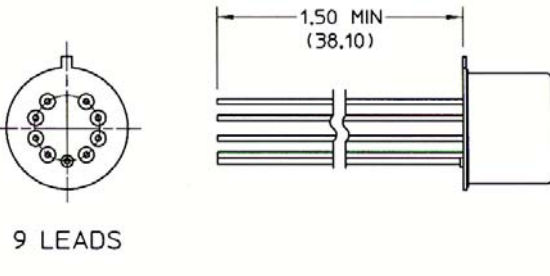
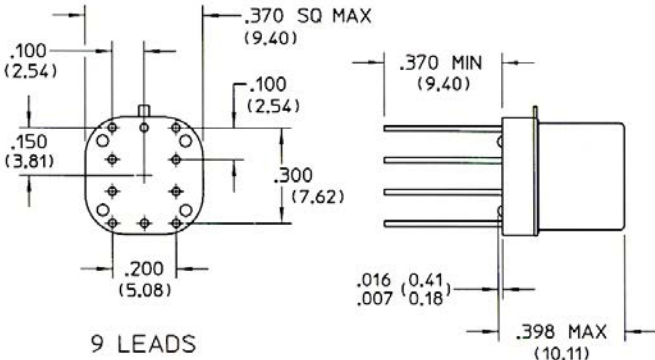
Appendix A. Mounting and Termination Variants (Cont'd).

Mounting	Termination	Configuration
Y	No Code G Q	 <p>.750 MIN (19.05)</p> <p>9 LEADS</p>
Y	S SG SQ	 <p>.187 ±.010 (4.75 ±.25)</p> <p>9 LEADS</p>
Y	W WG WQ	 <p>1.50 MIN (38.10)</p> <p>9 LEADS</p>
YM	No Code G Q	 <p>.100 (2.54)</p> <p>.150 (3.81)</p> <p>.200 (5.08)</p> <p>.370 SQ MAX (9.40)</p> <p>.100 (2.54)</p> <p>.300 (7.62)</p> <p>.370 MIN (9.40)</p> <p>.016 (0.41) .007 (0.18)</p> <p>.398 MAX (10.11)</p> <p>9 LEADS</p>

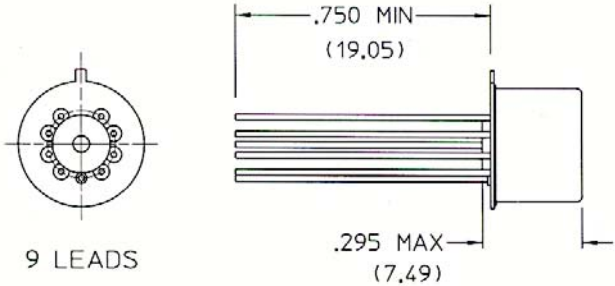
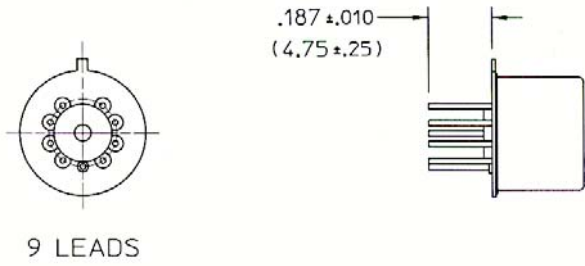
Appendix A. Mounting and Termination Variants (Cont'd).

Mounting	Termination	Configuration
YM4	No Code G Q	 <p>9 LEADS</p>
YM4	S SG SQ	 <p>9 LEADS</p>
YZ	No Code G Q	 <p>10 LEADS</p>
YZ	S SG SQ	 <p>10 LEADS</p>

Appendix A. Mounting and Termination Variants (Cont'd).

Mounting	Termination	Configuration
YZM	No Code G Q	<p>10 LEADS</p>
Z	No Code G Q	<p>9 LEADS</p>
Z	S SG SQ	<p>9 LEADS</p>
Z	W WG WQ	<p>9 LEADS</p>

Appendix A. Mounting and Termination Variants (Cont'd).

Mounting	Termination	Configuration
ZM	No Code G Q	<p>9 LEADS</p>
ZM4	No Code G Q	<p>9 LEADS</p>
ZM4	S SG SQ	<p>9 LEADS</p>

Appendix B. Document Change History.

Issue or Amendment No.	Date of Issue	Reference and Change Description	Change Notice No.
Issue 1	27 Feb 2001	Official Release	26633
Issue 2	18 Jan 2006	Revise Maximum Operate Time Limit	28409
Issue 3	31 Oct 2013	Update Vibration (Sinusoidal) Requirements	30554