



TELEDYNE
MICROWAVE SOLUTIONS
Everywhereyoulook™

TELEDYNE WHITE PAPER

SSPA Technology Achieves 10 kW, CW, at S-Band

*Stephen D. Turner, PE, Engineering Director,
Teledyne Paradise Datacom
Tom Dekker, Cree, Inc.*

A White Paper from Teledyne Paradise Datacom | paradisedata.com

SSPA Technology Achieves 10 kW, CW at S-Band

*Stephen D. Turner, PE, Engineering Director,
Teledyne Paradise Datacom
Tom Dekker, Cree, Inc.*

A White Paper from Teledyne Paradise Datacom | paradisedata.com

Abstract — This paper discusses the present state of the art in S-Band high power amplifier (HPA) design. A 10 kW CW Solid State Power Amplifier has been designed using solid state technology at 2 GHz. The SSPA utilizes the latest GaN HEMT device technology to meet the needs of high power S-Band satcom amplifiers to replace current traveling wave tube amplifier (TWTAs) systems.

Index Terms — GaN HEMT, GaAs Mesfet, Linearizer, Solid State Power Amplifier (SSPA), High Power Amplifier (HPA), Satcom.

I. Introduction

Solid State Power Amplifiers (SSPAs) have been dramatically evolving over the past thirty years. Microwave amplifiers have been a driving force in EW and Radar systems, terrestrial communication, wireless infrastructure, instrumentation and EMC applications as well as satellite communications. Satellite communication (satcom) amplifiers are used in base station - earth station installations and have some of the most stringent requirements of all amplifier applications. Satcom amplifiers are required to operate continuously and must provide linear power amplification. This presents a challenge to the amplifier engineer in that both efficiency and power density are of paramount importance in the design of satcom amplifiers. The requirement for linear output power means that the amplifier must be operated at an output power level far below its maximum saturated output power capability. Often a satcom amplifier is operating in a multicarrier environment carrying anywhere from ten to over fifty carriers.

II. Satcom Amplifier Technology

Due to the very high linear output power levels required to transmit multicarrier signals to satellite, satcom earth station amplifiers have been dominated by klystron and traveling wave tube amplifiers in the past. Because of the continuous operation requirement and extremely high collector operating temperatures, tube based amplifiers have experienced reliability problems. Since the emergence of gallium arsenide (GaAs) power transistors in the late 1970s, solid state amplifiers gradually began to replace klystron and traveling wave tube amplifiers (TWTAs) in

applications where sufficient linear power could be produced. Over the past two decades, GaAs devices have evolved such that SSPAs have become the preferred choice for earth station amplifier installations. Output power levels up to 1 kW have been achieved at S-Band, 4 kW at C-Band, 1 kW at X-Band and Ku Band and 50 W at Ka Band using GaAs FET technology. A combination of innovative power combining techniques and redundant, soft-fail, architectures have given SSPAs a dominant position in the market. Despite this evolution there remain applications that require even greater linear output power levels that until recently have still required the use of traveling wave tube amplifiers. As the available output power levels from GaAs FET devices have reached their limit amplifier designers have been in need of solid state devices with greater power density along with higher channel temperature operation. The advent of Gallium Nitride solid state device technology gives amplifier designers the ability to take SSPA power levels three to five times higher than what is presently possible with GaAs technology.

The advent of Gallium Nitride solid state device technology gives amplifier designers the ability to take SSPA power levels three to five times higher than what is presently possible with GaAs technology.

III. Gallium Nitride Device Technology

Cree Inc. pioneered the development of GaN-on-SiC HEMT technology and has been a leading supplier since GaN HEMT production release in 2006. The first production process was a 28V 0.4um GaN HEMT technology for high power UHF through C

SSPA Technology Achieves 10 kW, CW, at S-Band

band. Cree released 40V, 0.25um and 50V, 0.4um processes to extend the frequency range through Ku Band and support larger power requirements. The various processes allow the best fit to the application including multi-octave, high power pulsed, high power CW, linear applications for markets such as point-point radio, Satellite Communications, Cellular, Instrumentation and Medical and Military. The Teledyne application is an excellent example of an innovative approach to achieving the power and efficiency advantages of GaN HEMT for S Band applications. The market adoption for GaN HEMT has accelerated in recent

Cree offers a wide range of GaN HEMT products in either die form, packaged transistors or packaged MMICs. Table 1 gives an overview of Cree GaN technology. Additional information can be found at: <http://www.cree.com/rf/products>.

IV. S-BAND SSPA Module Design

The 10 kW S-Band SSPA system is designed around the Cree CGH21240F device. The CGH21240F is an internally input matched 28V, 240W GaN HEMT transistor optimized for operation in the 1.8GHz to 2.2GHz range. The transistor offers greater than 16dB power gain, greater than 53dBm output power and greater than 64% drain efficiency under pulsed conditions.







Frequency Range	GaN HEMT Product Families	
S Band	CGH2xxxx Series Up to 240W Packaged Transistor	
	CGH3xxxx Series Up to 240W Packaged Transistor	
C Band	CMPA5585025F 25W Packaged MMIC	
X Band	CMPA801B025F 25W Packaged MMIC	
	CGHV96xxx Series 50W & 100W Packaged Transistor	
Ku Band	CGHV1Jxxx Die Form Transistors	

Table 1. GaN Devices Manufactured by Cree

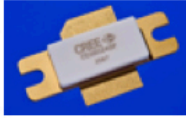
years for high power, high frequency solid state power amplifiers. GaN HEMT technology has proven itself to be highly reliable and rugged. Cree has fielded over 2 billion GaN HEMT devices hours with a field FIT rate of less than 10. The technology is thermally rugged and supports operational junction temperatures of 225C at excellent mean time to failure (MTTF) exceeding 2 million hours.

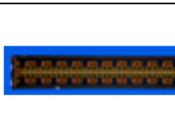
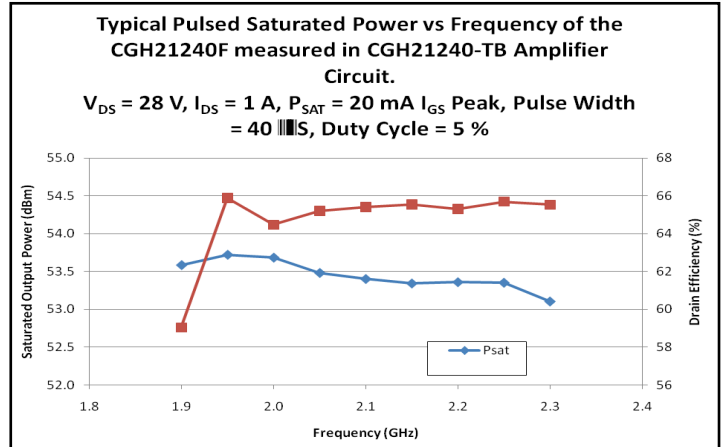

Figure 1. CGH21240F Typical Power vs. Frequency

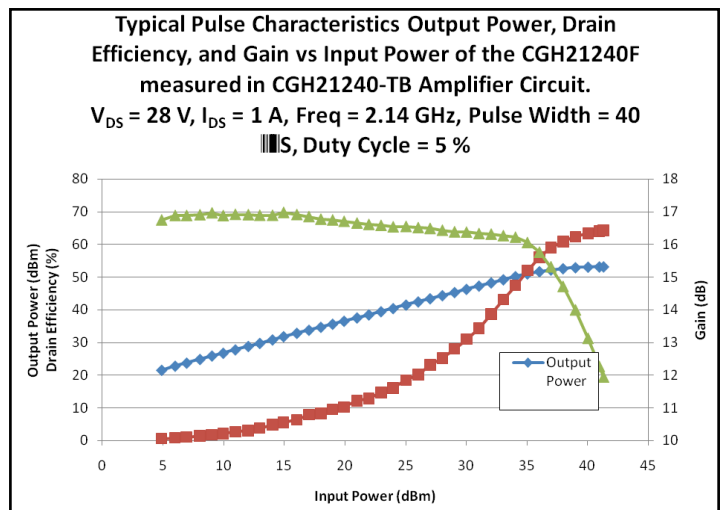

Figure 2. CGH21240F Typical Swept Power Performance

SSPA Technology Achieves 10 kW, CW, at S-Band

The amplifier system is designed using an array of phase combined SSPA modules. The SSPA module uses one Cree CGH21240F driving four phase combined devices as shown in Figure 3.

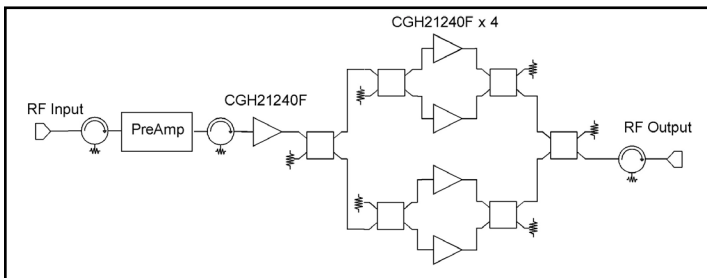

Figure 3. Block Diagram, 800 W S-Band SSPA Module

This results in a module that produces a minimum output power of 800W in the 2.0 GHz range. The CGH21240F's are then driven by a preamplifier section. The preamplifier contains additional GaN and GaAs FET driver stages along with a variable attenuator for amplifier gain adjustment. Also included in the preamplifier section is an analog predistortion linearizer. The linearizer serves to shape the GaN HEMT's power transfer curve shown in Figure 2 to behave similar to a GaAs FET's hard limiting characteristic. This increases the 1 dB compression point of the amplifier and improves the overall intermodulation distortion performance.

The nonlinear modeling allows the designer to optimize the tradeoffs among output power, efficiency, and intermodulation performance.

The CGH21240F is biased in mid class AB mode. The initial impedance matching was performed using the large signal device impedance provided by Cree [1]. The matching networks are

then optimized using the nonlinear device model provided by Cree in a Harmonic Balance simulator. The nonlinear modeling allows the designer to optimize the tradeoffs among output power, efficiency, and intermodulation performance.

The module is physically realized using softboard Microstrip techniques. The 800W module along with preamplifier and linearization circuitry is shown in Figure 4.

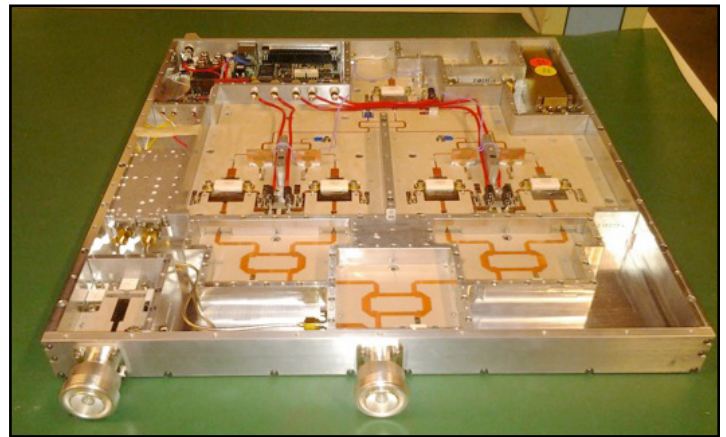

Figure 4. 800W S-Band SSPA Module Assembly

V. SSPA System Design

The amplifier system is a modular soft-fail architecture based on Teledyne Paradise Datacom's patented PowerMAX technology [2]. Eight discrete (800W) SSPA modules are phase combined to produce over 5 kW of saturated CW output power after the RF combining losses. The eight modules are arranged in a single cabinet and are powered by n+1 redundant (28 VDC) power supplies. The eight SSPA modules are phase combined using specially designed spatial and waveguide combiner arrays integrated in the amplifier cabinet. The 5 kW SSPA cabinet block diagram is shown in Figure 5.

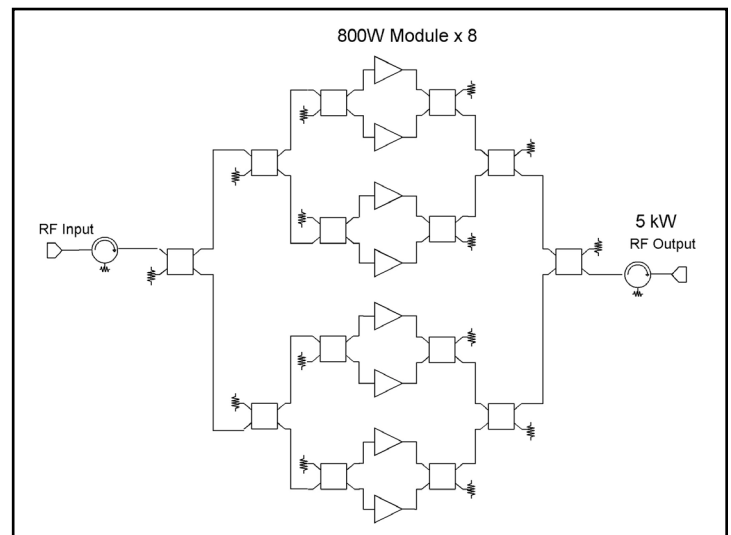

Figure 5. 5kW, S-Band SSPA Block Diagram



"The PowerMAX architecture is considered a self redundant system."



Figure 6. Single Cabinet 5kW, S-Band SSPA System

Figure 7. 10kW S-Band Phase Combined Amplifier System

The PowerMAX architecture is considered a self redundant system. The failure of one entire SSPA module results in a reduction of 1.2 dB in output power capability from the cabinet. The PowerMAX architecture allows modular amplifier architectures to achieve extremely high output power levels. The sophisticated embedded control intelligence allows the system to be operated as a 'single-box' amplifier.

The SSPA modules as well as the power supply modules are removable from the front panel of the equipment chassis. This facilitates very easy maintenance and replacement of the modules. Forced convection air cooling is used for the heat

transfer through the cabinet. The thermal design maintains device flange temperatures at less than 50 degrees C. The low-loss passive combining array provides a robust, soft-fail architecture.

Two identical 5 kW SSPA cabinets are then phase combined using a waveguide hybrid combiner in WR430. This creates a system comprised of 16 parallel combined 800W SSPA modules. The PowerMAX system architecture enables system configurations up to 16 modules. In a 16 module system, the failure of one SSPA module results in a reduction of 0.6 dB in output power capability [3].

Conclusion

There has been much published about very high power SSPAs in the pulsed and radar genre. Many have held the position that solid state power amplifiers are not able to achieve multi-kilowatt CW power levels. The maturation of GaN technology now dispels this myth with amplifier systems such as the 10 kW S-Band HPA described in this paper. The marriage of GaN HEMT technology and the PowerMAX redundant system architecture produces an outstanding HPA system for demanding satcom earth station installations. The combination of mid class AB bias and analog

The soft-fail characteristics and hot-swap field replaceable modules achieve system reliability figures that TWTA systems cannot achieve.

predistortion enable the GaN HEMT SSPA to have a similar intermod characteristic as its GaAs FET counterpart. The two-tone intermod vs. back off plot is shown in Figure 8.

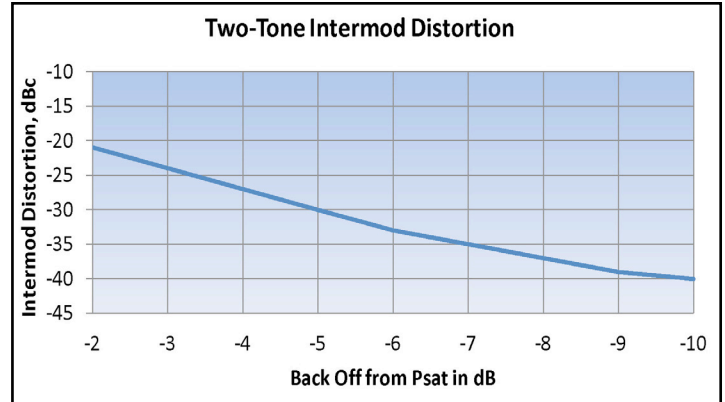

Figure 8. 10kW HPA Two-Tone Intermod Performance

The soft-fail characteristics and hot-swap field replaceable modules achieve system reliability figures that TWTA systems cannot achieve. GaN technology enables this system to approach similar prime power to linear RF output power efficiency as TWTAs. As device manufacturers such as Cree

continue to push the envelope of GaN technology, SSPA systems will become more versatile, covering wider bandwidths and higher frequency bands. GaN based PowerMAX systems have already been manufactured in all of the major satcom frequency bands. The current state of the art is:

- ▶ S-Band (2.0 – 2.3 GHz): 10 kW
- ▶ C-Band (5.8 – 6.5 GHz): 8 kW
- ▶ X-Band (7.9 – 8.4 GHz): 6 kW
- ▶ Ku-Band (13.75-14.5 GHz): 3.0 kW
- ▶ Ka-Band (29.0-31.0 GHz): 1.0 kW

The authors would like to acknowledge the contributions of the amplifier design team members: Craig Harris, Oleg Karpenko, Sithorn Prak, Dave Johnson, and Jason Fetters.

References

- [1] Ali A. Behagi, Stephen D. Turner, *Microwave and RF Engineering, Volume 1 An Electronic Design Automation Approach*, BT Microwave LLC, 2011.
- [2] Paradise Datacom LLC, "Power Amplifier System" U.S. Patent 8,189,338 B2, May 29, 2012.
- [3] Stephen D. Turner, "Concepts in Communication Amplifier Redundancy Systems" *Armed Forces International, Dec. 2004*.

Teledyne Paradise Datacom
328 Innovation Blvd., Suite 100
State College, PA 16803 USA
Tel: 1 (814) 238-3450
Fax: 1 (814) 238-3829



LLC Teledyne Paradise Datacom Ltd.
2&3 The Matchyns, London Road, Rivenhall End
Witham, Essex, CM8 3HA United Kingdom
Tel: +44(0) 1376 515636
Fax: +44(0) 1376 533764
