

The New Standard in Outdoor High Power Redundant Microwave Amplifier Systems Has Arrived

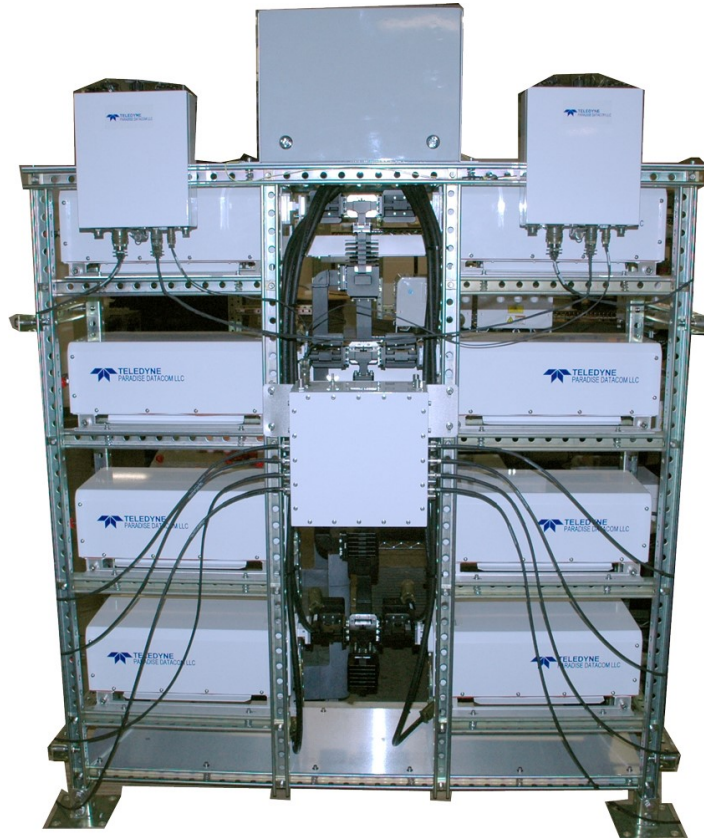

1.6 kW C-Band SSPA System configured with (8) 250W Modules

FEATURES

- Gallium Arsenide Compact Outdoor SSPA modules
- Each array of 4 HPAs features no active switching - all passive Power Combining
- Output Power sized for N+1 Redundancy
- System can be configured with any combination of 4 to 16 units
- Removable fan trays
- 100% field maintainable
- System Monitor and Control emulates single SSPA Chassis operation
- Legacy RS-485 M&C
- Ethernet Port with UDP, SNMP, and internal web browser capability
- Accurate Output Power measurement
- Hot/Cold Standby operating modes for reduced power consumption
- Reflected Power Monitor
- RF Output Sample Port
- Optional L-Band Input with Redundancy
- RF Gain Adjustment (50 dB - 70 dB)
- System is field scalable: i.e., can start out with (4) modules in system and upgrade to (8) modules.

PowerMAX is covered by U.S. Patent Nos. 8,189,338 B2 and 8,411,477 B2

www.paradisedata.com

System Operation

The Outdoor PowerMAX system maintains complete parallel redundancy down to the embedded control level. Therefore the loss of an entire amplifier will not interrupt remote communications with the system. Remote communications can be either RS-485 or Ethernet. The system will automatically correct its gain level in the event of one or more amplifier failures.

The sophisticated system monitor and control allows the system to be locally or remotely operated as if it were a “single” chassis amplifier. The system control maintains a hierarchical management that allows the operator to interface to a single chassis of the multi-module array.

Another feature unique to Teledyne Paradise Datacom’s Outdoor PowerMAX is the introduction of “true rms” output power measurement. Unlike other amplifier systems that utilize diode detection schemes, the Outdoor PowerMAX reports the true rms output power of the system independent of the number of carriers and modulation schemes.

Proprietary waveguide combining techniques are employed so that maximum power combining efficiency is optimized within the operating frequency band.

System Output Power and Configurations

The Outdoor PowerMAX system is typically used as a “self-redundant” system. The output power is sized such that the loss of (1) RF module’s power will still allow the system to maintain its minimum required output power. This type of system architecture is described as n+1 redundant. The system can be configured with any number of modules, but best overall efficiency is obtained with the popular binary combinations of 4 or 8 modules.

It is very easy to upgrade the PowerMAX system from 4 modules to 8 modules in the field. It is not necessary to fully populate the system at the time of initial purchase. This provides the user a path to upgrade output power capability as system requirements grow, thus keeping capital investment minimized. For sizing redundant output power capability use the following guideline to determine the output power of the system with the loss of (1) module.

4 Module System - 3 of 4 Modules Operable = 2.5 dB loss in output power capability

8 Module System - 7 of 8 Modules Operable = 1.2 dB loss in output power capability

16 Module System - 15 of 16 Modules Operable = 0.6 dB loss in output power capability

Hitless Redundancy

For mission critical systems in which no power outage can be tolerated, an eight module Outdoor PowerMAX system can be operated with only four modules installed. In this way, the additional four modules can be installed without requiring the system to be powered off.

The only disadvantage of operating the eight module Outdoor PowerMAX system with four modules is the additional 3 dB loss that the four module (half-system) system experiences by going through the final hybrid combiner as shown at right. The overall output power is therefore actually 6 dB below what it would be with all eight modules present.

If the module output power is sized such that this reduction in output power can be tolerated, the system shown at right is an effective means of scaling the system from four to eight modules and maintaining true hitless operation.

With parallel system architectures, the amplifier output power capability and gain will change as the number of active modules vary. The Outdoor PowerMAX system is designed with an Auto-Gain Control mode so that the overall system gain will remain constant in the event of a single module failure. See the table below.

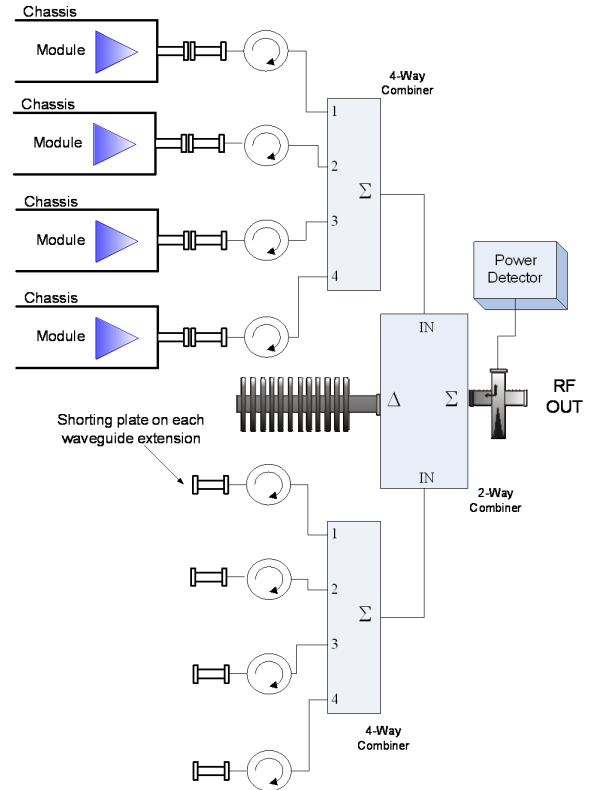

System Type	# Modules in System	Gain Change Auto Gain Control On	Gain Change Auto Gain Control Off	Maximum Output Power
4 Units	3 of 4	0 dB	-2.5 dB	-2.5 dB
4 Units	2 of 4	-1.0 dB	-6.0 dB	-6.0 dB
4 Units	1 of 4	-7.0 dB	-12.0 dB	-12.0 dB
8 Units	7 of 8	0 dB	-1.2 dB	-1.2 dB
8 Units	6 of 8	0 dB	-2.4 dB	-2.4 dB
8 Units	5 of 8	0 dB	-4.0 dB	-4.0 dB
8 Units	4 of 8	-1.0 dB	-6.0 dB	-6.0 dB
8 Units	3 of 8	-3.5 dB	-8.5 dB	-8.5 dB
8 Units	2 of 8	-7.5 dB	-12.5 dB	-12.5 dB
16 Units	15 of 16	0 dB	-0.6 dB	-0.6 dB
16 Units	14 of 16	0 dB	-1.2 dB	-1.2 dB
16 Units	13 of 16	0 dB	-2.0 dB	-2.0 dB
16 Units	12 of 16	0 dB	-2.5 dB	-2.5 dB

SSPA Module Population Options

The Outdoor PowerMAX system is available in a variety of system GaAs module configurations and output power levels. The system is based on Teledyne Paradise Datacom's popular Compact Outdoor SSPA. The units can be configured with a wide variety of SSPA frequency bands and power levels, and can be fitted with the following SSPA modules:

- **C-Band:** **100W, 140W, 200W, 250W, 300W**
- **X-Band:** **200W**



Single Unit Mechanical & Environmental Specifications

PARAMETER	NOTES	LIMITS	UNITS
Size	width X length X height	9.0 X 12.0 X 6.5 229 X 305 X 165	inches mm
Weight	Base unit	24.5 (11.2)	lbs. (kg)
Finish		powder coat	white
Operating Temperature	Ambient	-40 to +60	°C
Relative Humidity	Condensing	100	%
Cooling System	Integrated	Forced air	
Ingress Protection Rating	With connectors properly sealed	IP54	
Altitude	No temperature de-rating up to 10,000 ft. (3,000 m) De-rate maximum temperature by 2 °C per 1,000 ft (300 m) beyond 10,000 ft.		
Shock	50 g p-p, 11 msec pulses		
Vibration	3g rms 30 min. 5-2000 Hz		

4 Module C-Band Outdoor PowerMAX System Power Specifications

SSPA Module Power Level	4 Module GaAs Compact RF Output Power		AC Input Power (W)	3 Module Redundant RF Output Power	
	P _{sat} , typical dBm (W)	P _{1dB} , min. dBm (W)		P _{sat} , typical dBm (W)	P _{1dB} , min. dBm (W)
100 W	55.2 (331)	54.7 (295)	3200	52.8 (191)	52.3 (170)
140 W	56.7 (468)	56.2 (417)	3700	54.3 (269)	53.8 (240)
200 W	58.2 (661)	57.5 (562)	5500	55.8 (380)	55.1 (324)
250 W	59.2 (832)	58.2 (661)	6300	56.8 (479)	55.8 (380)
300 W	60.0 (1000)	59.2 (832)	7000	57.5 (562)	56.8 (479)

Note 1: For Frequency selection "B", de-rate output power by 1.0 dB linearly from 6.425 to 6.725 GHz.

Note 2: For Frequency selection "C", de-rate output power by 1.0 dB linearly from 5.850 to 5.750 GHz and by 1.0 dB linearly from 6.425 to 6.670 GHz.

4 Module X-Band Outdoor PowerMAX System Power Specifications

SSPA Module Power Level	4 Module GaAs Compact RF Output Power		AC Input Power (W)	3 Module Redundant RF Output Power	
	P _{sat} , typical dBm (W)	P _{1dB} , min. dBm (W)		P _{sat} , typical dBm (W)	P _{1dB} , min. dBm (W)
200 W	58.2 (661)	57.0 (501)	6000	55.8 (380)	54.6 (288)

Continuous operation at saturated power can negatively impact the life of the amplifier and will not be covered by warranty. Normal operating output should be limited to P_{1dB} (1dB backed off from the full rated power, P_{sat}).

8 Module C-Band Outdoor PowerMAX System Power Specifications

SSPA Module Power Level	8 Module GaAs Compact RF Output Power		AC Input Power (W)	7 Module Redundant RF Output Power	
	P _{sat} , typical dBm (W)	P _{1dB} , min. dBm (W)		P _{sat} , typical dBm (W)	P _{1dB} , min. dBm (W)
100 W	58.0 (631)	57.5 (562)	6200	56.8 (479)	56.3 (427)
140 W	59.5 (891)	59.0 (794)	7200	58.3 (676)	57.8 (603)
200 W	61.0 (1259)	60.3 (1072)	10500	59.8 (955)	59.1 (813)
250 W	62.0 (1585)	61.0 (1259)	12400	60.8 (1202)	59.8 (955)
300 W	62.7 (1862)	62.0 (1585)	13500	61.5 (1413)	60.8 (1202)

Note 1: For Frequency selection "B", de-rate output power by 1.0 dB linearly from 6.425 to 6.725 GHz.

Note 2: For Frequency selection "C", de-rate output power by 1.0 dB linearly from 5.850 to 5.750 GHz and by 1.0 dB linearly from 6.425 to 6.670 GHz.

8 Module X-Band Outdoor PowerMAX System Power Specifications

SSPA Module Power Level	8 Module GaAs Compact RF Output Power		AC Input Power (W)	7 Module Redundant RF Output Power	
	P _{sat} , typical dBm (W)	P _{1dB} , min. dBm (W)		P _{sat} , typical dBm (W)	P _{1dB} , min. dBm (W)
200 W	61.0 (1259)	59.8 (955)	11500	59.8 (955)	58.6 (724)

Continuous operation at saturated power can negatively impact the life of the amplifier and will not be covered by warranty. Normal operating output should be limited to P_{1dB} (1dB backed off from the full rated power, P_{sat}).

16 Module C-Band Outdoor PowerMAX System Power Specifications

SSPA Module Power Level	16 Module GaAs Compact RF Output Power		AC Input Power (W)	15 Module Redundant RF Output Power	
	P _{sat} , typical dBm (W)	P _{1dB} , min. dBm (W)		P _{sat} , typical dBm (W)	P _{1dB} , min. dBm (W)
100 W	60.8 (1200)	60.3 (1060)	12,400	60.2 (1035)	59.7 (925)
140 W	62.3 (1700)	61.8 (1500)	14,400	61.7 (1465)	61.2 (1300)
200 W	63.8 (2370)	63.1 (2020)	21,000	63.2 (2065)	62.5 (1760)
250 W	64.8 (3000)	63.8 (2400)	24,800	64.2 (2600)	63.2 (2065)
300 W	65.5 (3500)	64.8 (3000)	27,000	64.9 (3054)	64.2 (2600)

Note 1: For Frequency selection "B", de-rate output power by 1.0 dB linearly from 6.425 to 6.725 GHz.

Note 2: For Frequency selection "C", de-rate output power by 1.0 dB linearly from 5.850 to 5.750 GHz and by 1.0 dB linearly from 6.425 to 6.670 GHz.

16 Module X-Band Outdoor PowerMAX System Power Specifications

SSPA Module Power Level	16 Module GaAs Compact RF Output Power		AC Input Power (W)	15 Module Redundant RF Output Power	
	P _{sat} , typical dBm (W)	P _{1dB} , min. dBm (W)		P _{sat} , typical dBm (W)	P _{1dB} , min. dBm (W)
200 W	63.8 (2370)	62.6 (1800)	23,000	63.2 (2065)	62.0 (1570)

Continuous operation at saturated power can negatively impact the life of the amplifier and will not be covered by warranty. Normal operating output should be limited to P_{1dB} (1dB backed off from the full rated power, P_{sat}).

Common Electrical Specifications

PARAMETER	NOTES	LIMITS	UNITS
Gain	range	55-75	dB
Gain Flatness	full band	± 1.0	dB
Gain Slope	full band (Extended C-Band)	± 1.5	dB
Gain Variation vs. Temperature	per 40 MHz	± 0.3	dB/40 MHz
Gain Stability	-30 °C to +50 °C	± 1.5	dB
Gain Adjustment	at constant temperature	± 0.25	dB/24 hours
	0.1 dB resolution	20	dB
Intermodulation Distortion (Two-tone, 5 MHz spacing)	@ P _{1dB} - 3 dB	-25	dBc
AM/PM Conversion	@ rated P _{1dB}	3.5	°/dB
	@ rated P _{1dB} -1 dB	1.5	°/dB
	@ rated P _{1dB} -2 dB	1.0	°/dB
Spurious Harmonics (SSPA only)	@ rated P _{1dB}	-65	dBc
	@ rated P _{1dB} - 3 dB	-50	dBc
Input VSWR	Extended C-Band	≤ 1.30 : 1	
Output VSWR		≤ 1.50 : 1	
		≤ 2.00 : 1	
Group Delay (per 40 MHz segment)	Linear	0.01	ns/MHz
	Parabolic	0.003	ns/MHz ²
	Ripple	1.0	ns p-p
Transmit Band Noise	TX Band	-75	dBW/4 KHz
Output Power Density	RX Band	-150	dBW/4 KHz
Residual AM Noise, typical	0 - 10 KHz	-45	dBc
	10 KHz - 500 KHz	-20 (1.25 + log F)	dBc
	500 KHz - 1 MHz	-80	dBc
Residual Phase Noise, typical (SSPA only)	Offset frequency from carrier		
	10 Hz	-90	dBc/Hz
	100 Hz	-100	dBc/Hz
	1 KHz	-110	dBc/Hz
	10 KHz	-120	dBc/Hz
	100 KHz	-125	dBc/Hz
	1 MHz	-130	dBc/Hz
True RF Power Detector	Range	P _{sat} to (P _{sat} - 20)	dB
	Accuracy	± 0.5	dBm

Specifications are subject to change without notice.

L-Band Input Option

The Outdoor PowerMAX system can be configured for L-Band Input operation. For optimum RF phase combining over the entire bandwidth of a communication amplifier system, the frequency translation part of the system must be separated from the phase combined loop. Therefore, systems with L-Band input are configured with a separate L-Band block up converter system that feeds the PowerMAX system.

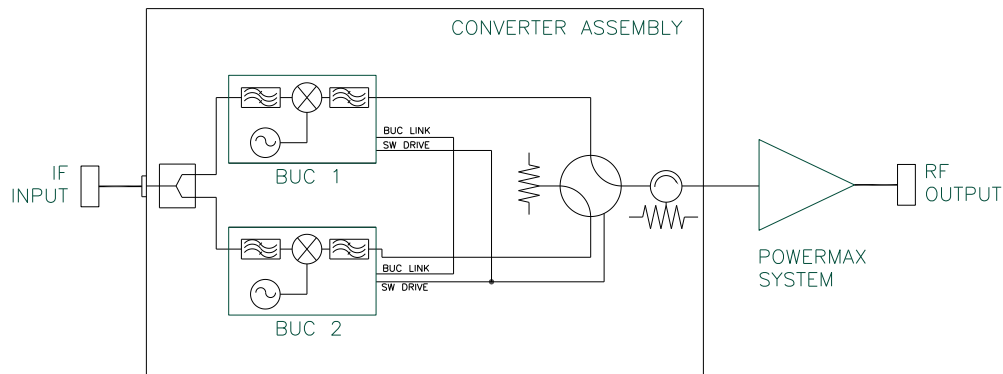

Simplified Block Diagram, Redundant Converter Assembly with Outdoor Controller

The block up converter system is a 1:1 redundant block up converter assembly with internal redundancy control. The Teledyne Paradise Datacom converter architecture allows a converter that is fitted with an internal reference oscillator to automatically detect and switch to an externally applied 10 MHz reference signal.

When a fault is detected in the online converter, the redundancy controller drives the switch to place the standby BUC online without user intervention.

If L-Band redundancy is not required, the system can be configured with a single thread block up converter.

Global Sales Offices

U.S., Canada, Latin America

Teledyne Paradise Datacom
11361 Sunrise Park Drive
Rancho Cordova, CA 95742
Tel: +1 (814) 954-6163
sales@paradisedata.com

Eastern Regional Sales Office

(Eastern U.S. & Latin America)
RF Inquiries: John O'Grady, (848) 220-6464
Modem Inquiries: Mike Towner, (470) 509-9941
sales@paradisedata.com

Western Regional Sales Office

(Western U.S. & Canada)
Bruce Grieser
Cell: +1 (480) 444-9676
sales@paradisedata.com

U.K. Office

Europe, Middle East, Africa
Teledyne Paradise Datacom
106 Waterhouse Lane,
Chelmsford, Essex, England, CM1 2QU
Tel: +44(0)1245 847520
Tel: +44(0)1376 515636
sales@paradisedata.com

Asia Pacific

Tavechai Mektavepong
Teledyne Paradise Datacom Thailand Office
333, 20 C1 Fl., Lao Peng Nguan Tower 1,
Vibhavadi-Rangsit Rd.,
Chomphol, Chatuchak,
Bangkok 10900
Thailand

Tel: +66 2-272-2996
Fax: +66 2-272-2997
sales@paradisedata.com

Beijing, China

Teledyne Paradise Datacom Representative Office
Room 204, No.1 Building,
No.9 Jiuxianqiao East Road,
Chaoyang District,
Beijing, China 100016

Tel: +86 13601251528
sales@paradisedata.com

Use and Disclosure of Data: This product is classified as EAR99 and is subject to U.S. Department of Commerce regulations. Export, reexport or diversion contrary to U.S. law is prohibited.

Proprietary and Confidential: The information contained in this document is the sole property of Teledyne Paradise Datacom. Any reproduction in part or as a whole without the written permission of Teledyne Paradise Datacom is prohibited.

Data Security: Teledyne Paradise Datacom amplifiers and controllers do not inherently provide encryption to transmitted data, and have limited security measures to protect it. If the unit will be accessible over the Internet, exercise appropriate data security protocols. Teledyne Paradise Datacom strongly recommends placing the equipment behind a protective Firewall or setting up a VPN link with dual authentication for remote access.

Specifications are subject to change without notice.