

Keeping Defense Platforms Alive in a World of Decreasing Semiconductor Availability

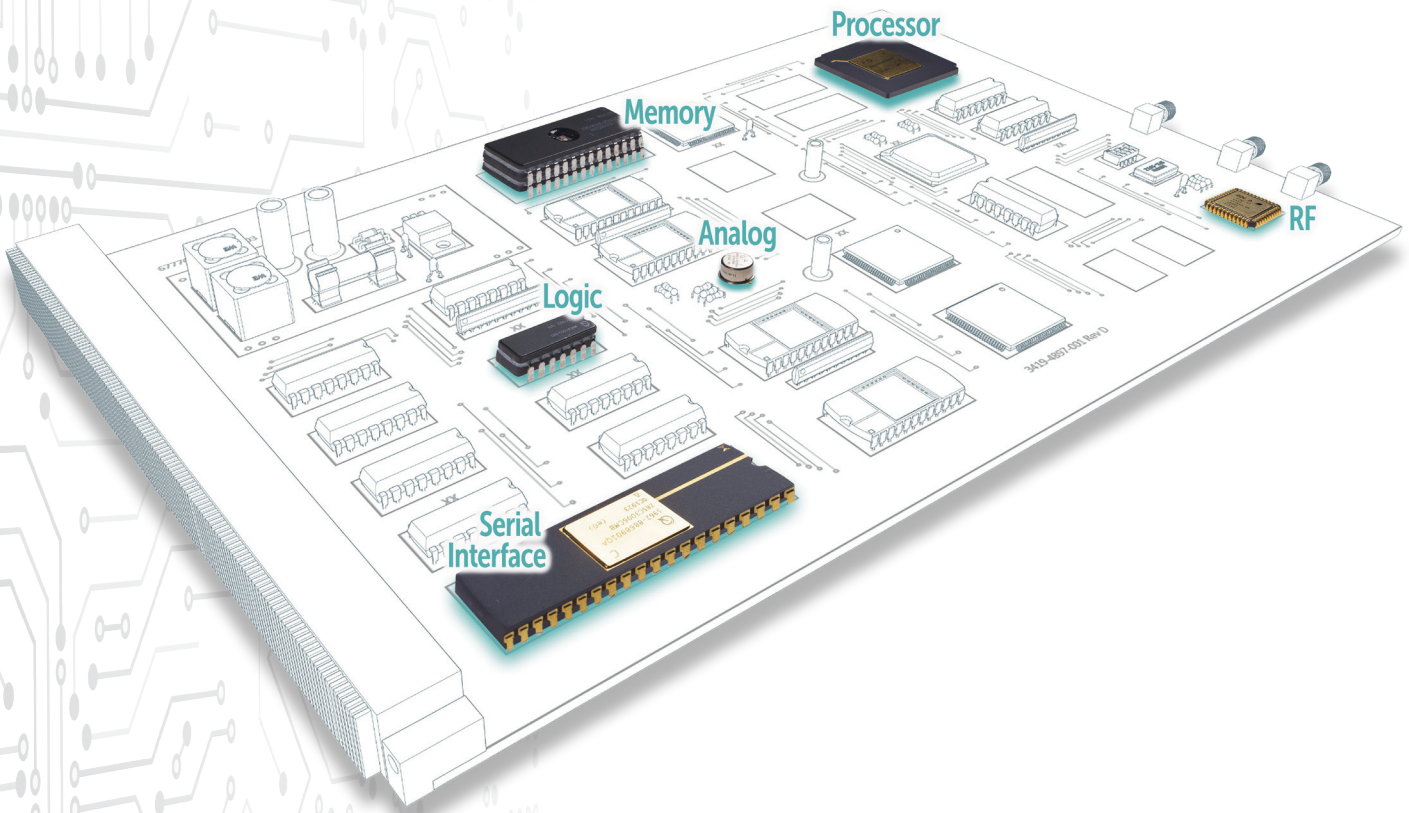

Keeping Defense Platforms Alive in a World of Decreasing Semiconductor Availability

Introduction

Originally, defense was the main driver of semiconductor design, and the two industries aligned well. In the decades since, the semiconductor business has become dominated by the needs of the commercial sector, with defense usually an afterthought. One consequence of this is that the availability of many commercial semiconductor parts useful to the defense industry can be measured in months, or at most a handful of years. This has a profound impact on the defense industry. In parallel, many countries are also choosing to extend the working life of big defense platforms rather than invest in ground-up replacements. Taken together, these two trends make the sourcing of semiconductors over the long term a major worry. This mismatch is illustrated in Figure 1, where the phases are typically measured in decades.



To compound the pain, a significant trend is that many semiconductor manufacturers that formerly supplied the defense and space markets are abandoning the segments in favor of easier, higher volume opportunities such as 5G telecom. This only makes the sourcing of semiconductors worse.

Note that even for new platforms, the time delay between component selection and ramping to volume will be significantly beyond the availability of most commercial parts, so that chip availability impacts new platforms as well.

This paper looks at ways of successfully managing the supply of critical semiconductor parts over the long-term using Teledyne e2v's Semiconductor Lifecycle Management (SLiM™) program.

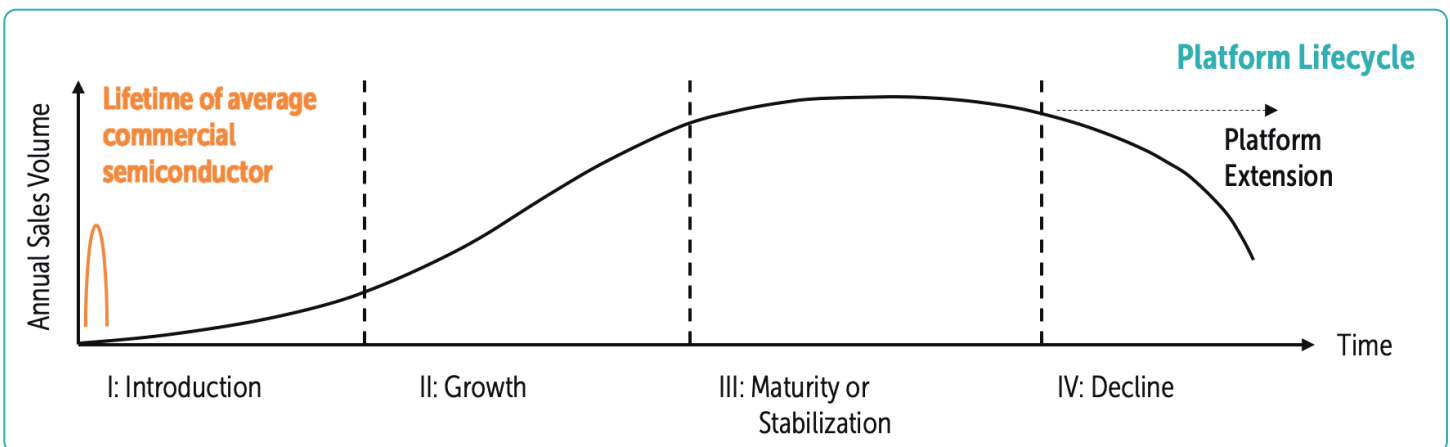

Figure 1: Mismatch between defense platform lifecycles and modern semiconductor lifetimes

Keeping Defense Platforms Alive in a World of Decreasing Semiconductor Availability

Imagine a Circuit Board...

For this tour we're going to use a hypothetical circuit board, as shown in Figure 2. For this example, it has a wide variety of component types and packaging classes, from logic, to processing, to RF. We will walk through some common issues and possible solutions, in each case also giving examples of success stories.

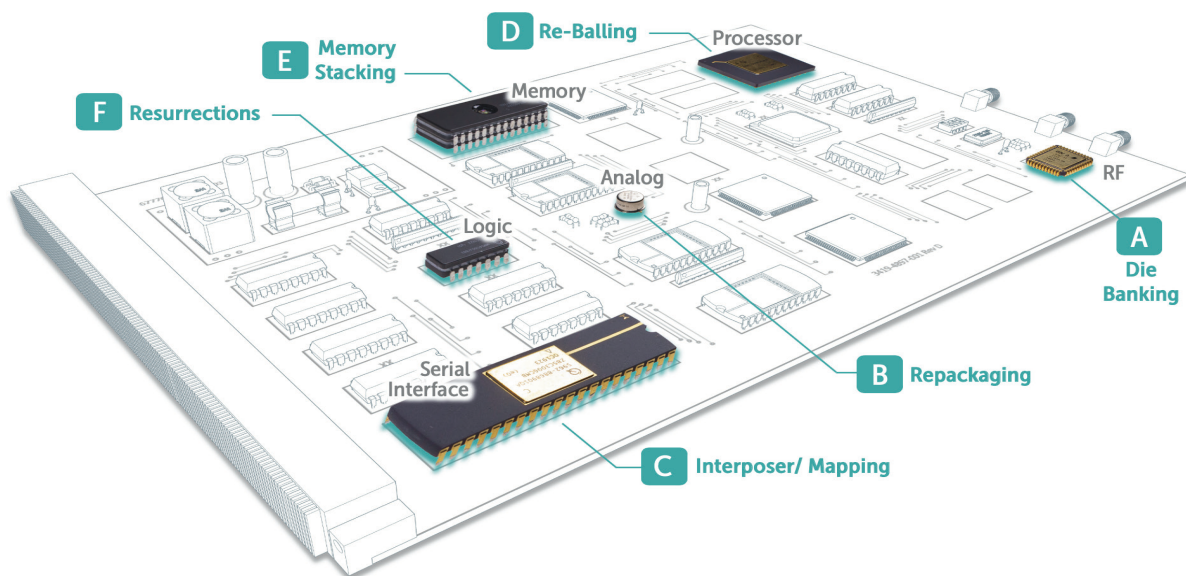

Figure 2: Generic circuit board showing example components and methods of assuring continuity of supply

It's Easier and Cheaper When You Plan Ahead

We're using the RF component labeled 'A' in Figure 2 as a proxy for probably the best way of managing parts obsolescence, which is die banking. Figure 3 shows a representation of the costs incurred once an End-of-Life (EoL) notice is received on a critical part, and it depends significantly on the planning that was performed beforehand.

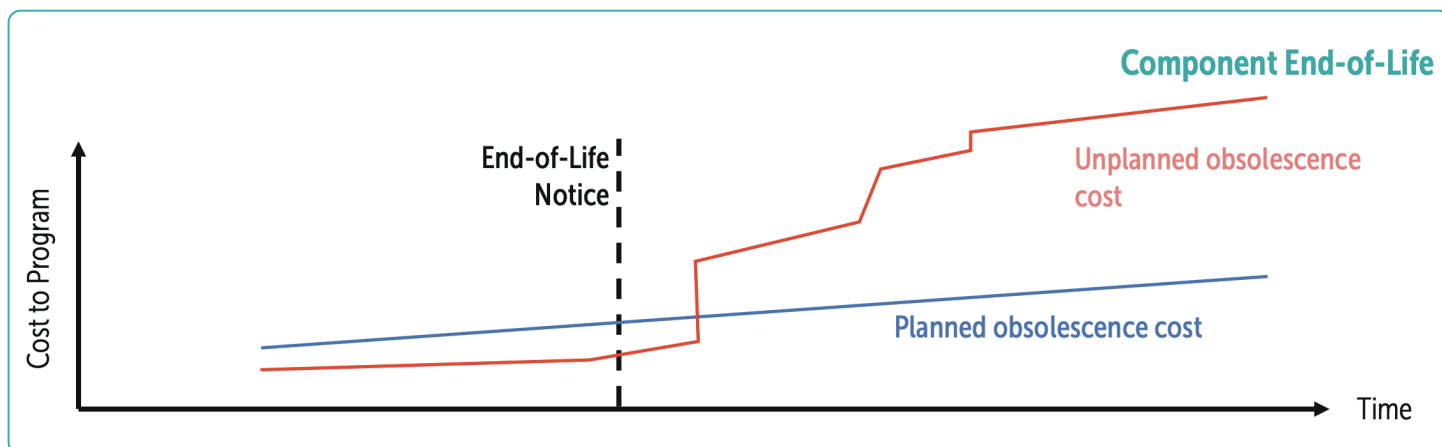

Figure 3: Planning for semiconductor obsolescence

Keeping Defense Platforms Alive in a World of Decreasing Semiconductor Availability



Teledyne e2v HiRel Electronics manages the banking of many thousands of wafers in safe, environmentally controlled conditions. Many of these are inventory that we have purchased from other semiconductor suppliers who have wanted to dispose of them; we also manage wafers for clients who have carefully evaluated where they will be vulnerable on key programs and have contracted us for surety of supply. We have a variety of ways we can manage, package and qualify parts as needed. As shown in the graph, the higher up-front cost more than pays off over the long term, particularly as it can avoid the panics and disruption that can occur when an EoL notice is a surprise.

...But in Case You Didn't...

If you were unable to plan ahead, or the items you stored ran out or were not the right ones, it is possible we can either source them from the open market or from our extra inventory if available. Examples of our extensive collection include:

- Cypress 37K CPLDs
- IDT FCT logic
- National Semiconductor military logic families

Below are some other options and services we have used in the past to help customers keep platforms alive.

Repackaging

While some devices may still be available, they may not be obtainable in the ruggedized or specialized packaging required for a particular program. A couple of examples of repackaging we've performed are shown here.



Missile

- LM741
- Custom Gull Wing Package
- HiRel qualified to customer specification

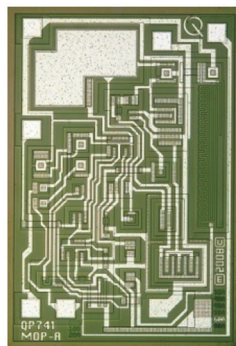

SDR Handheld Radio

- Existing RF Synthesizer package went EoL
- Teledyne HiRel able to offer suitable package, assembly & test to avoid line-down
- Protos shipping Feb 2020



Keeping Defense Platforms Alive in a World of Decreasing Semiconductor Availability

Interposer/Pin-Mapping

A related area to repackaging, interposing (also sometimes called pin-mapping) is the ability to take parts with functions required to keep a circuit functioning and create suitable interposers to allow the device to directly replace obsolete parts without needing to change on-board layout. It is much quicker and less expensive to do an interposer for a standard part that is already tested than to have to find, buy, and repackage a die which then has to be tested again and qualified. Often the functionality needed is not even available in die form but is available as a packaged part with a different pin-out or form factor than required. The designing of an interposer often allows such parts to be used without board changes.

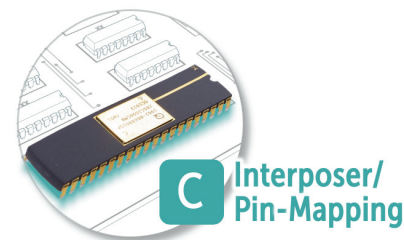

A recent example where we've successfully helped a customer is shown below.

Fighter Aircraft EW System

Problem

- MUX/DeMUX EoL issued

Solution

- Teledyne HiRel was able to identify/ procure similar device/function
- Interposer designed to map new die to required pinout
- Device completed system level testing
- New device working "perfectly" in system

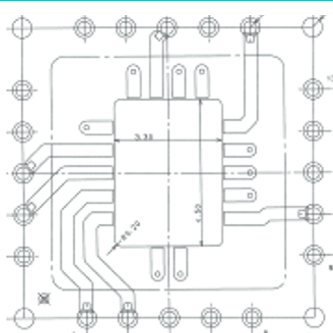

Re-Balling

An issue that applies equally to current and formerly available parts is the need to be able to use tin lead solder. All new semiconductors utilize RoHS compliant packaging, and lead-free does not meet the needs of defense & space applications. We can re-process parts to have tin lead solder. This applies to BGA packages with solder balls, which can be converted from lead-free to tin-lead.

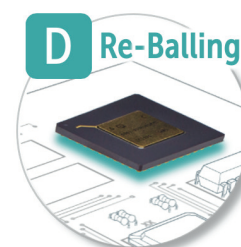

Memory Re-Ball

Problem

- Micron EoL notice for SnPb version
- Customer wanted long term support for SnPb option

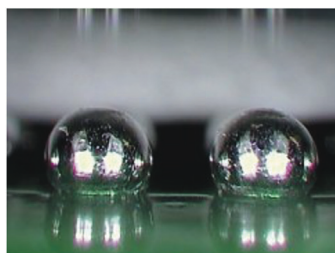

Solution

- Teledyne HiRel qualified to customer specification

Fighter Aircraft

Problem

- Lead-free parts included 16-Bit Bus Transceiver in 54-pin BGA package

Solution

- Re-ball of TI Lead Free Device
- Parametric Test
- Teledyne HiRel qualified to customer specification



Keeping Defense Platforms Alive in a World of Decreasing Semiconductor Availability

Memory Stacking

A common method of obtaining more memory on a given circuit layout is to stack memory chips on top of each other. Replicating this in a reliable, rugged and qualified way is challenging, to say the least. We have helped customers as part of resurrections, and also when their existing stacking supplier is failing to meet expectations.

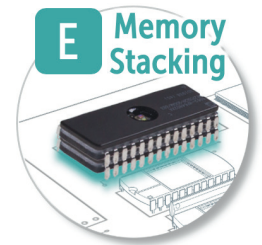

Avionic Application

Problem

- Existing memory stacking supplier EoL their offering

Solution

- Parts resurrection & memory stacking
- Pin compatible replacement for Crucial's 1G-bit DDR1 STARPAKS®
- Teledyne HiRel qualified to customer specification

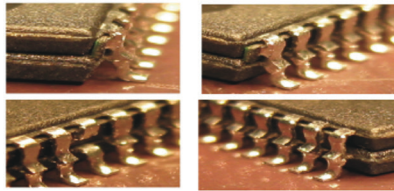

Helicopter

Problem

- Existing memory stacking supplier not meeting expectations
- EoL notice

Solution

- Teledyne HiRel qualified to customer specification

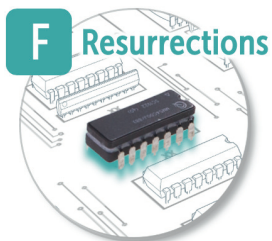
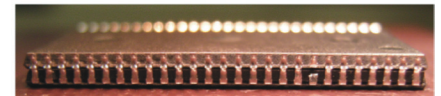

Parts Resurrection

When no wafers were set aside, no replacement parts can be bought on the open market, and no magic can be applied to repackage a modern part to fit a legacy application, all avenues are exhausted. At this point we are able to take a golden unit, and reverse engineer it from the ground up. We meticulously de-process the unit, use any documentation that might be available, and recreate new wafers from scratch. While this can be expensive, it assures supply for the foreseeable future, and is typically an order of magnitude lower in cost than the alternative of a board redesign. We have become expert at this through years of experience, including engineering in the necessary flaws that were present originally, but that modern techniques have otherwise eliminated.

Keeping Defense Platforms Alive in a World of Decreasing Semiconductor Availability

Fighter Aircraft

- Redesign of obsolete Motorola 10H558 with potential add-on of 8 additional Products
- Qualified to customer specification and generic part to allow drop in replacement

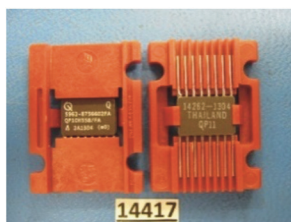

Avionic RWR

- Existing FIFO supplier EoL'd their offering
- Teledyne HiRel re-engineered die to EoL datasheet
- Protos delivered to customer
- Reliability testing underway



Atmel AT750BL UV Erasable PLD

- 0.45 μ m CMOS Process
- 5962-88726 Qualified
- Fab: Macronix, Taiwan

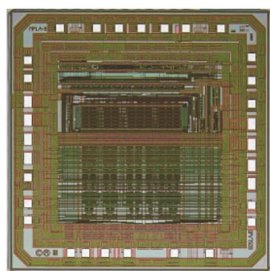

Missile

- Redesign of obsolete RM4260 with potential add on of the RA2916
- Qualify to customer specification and generic part to allow drop in replacement

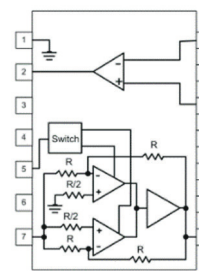

Cypress CY7C439 2Kx9 FIFO

- 5V CMOS 0.65 μ m Process
- Fab: X-FAB, Austin, TX

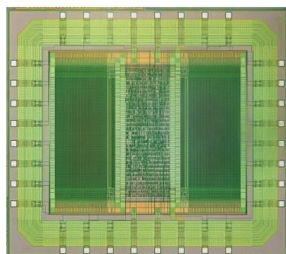

IDT 7025, 7133 8Kx16 and 2Kx16 DP SRAM

- 0.45 μ m CMOS Process
- 5962-91617 Qualified
- Fab: Macronix, Taiwan

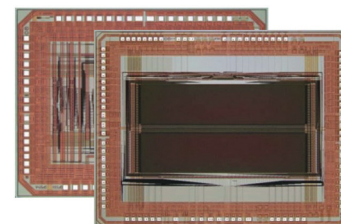

Parts Resurrection Case Study

A customer responsible for a major missile program was faced with a dilemma. The platform is decades old, and widely deployed. However, many parts are unavailable. One part that is used in every system was critical enough that the customer made arrangements for die banking in the early 2,000's. However, by 2013 even this stock was running out. Redesign and requalification of the parent circuit card was estimated to cost at least \$2M, and it was probable that a redesign would have a knock-on impact to adjacent cards, requiring changes to those, also. What to do?

Teledyne e2v HiRel Electronics partnered with the customer to produce a new part, with all of the behaviors of the old part. After 2 wafer spins and 18 months, the customer had samples in his hand, and a problem solved. He worked with the specialized design team at Teledyne who also ensured the part had the required custom packaging, and the part was fully qualified. The program now has assured product availability for the future. The customer is now using a derivative of the resurrected part on two different assemblies to assure continuation of a different missile program.

Keeping Defense Platforms Alive in a World of Decreasing Semiconductor Availability

Conclusion

It is certain that semiconductor availability will continue to be a poor match with defense development lifecycles, and lengthening platform extensions. Add into the mix the extra levels of performance, part qualification and custom packaging, and the defense and space industries become unattractive for most semiconductor suppliers, particularly when compared to volume opportunities such as 5G telecoms. However, there are options for ensuring availability of suitable parts in most situations, and this paper has shown some real examples of problems solved. These range from sourcing and die banking, to custom packaging and memory stacking, through to full wafer-up resurrection.

